

SEPT 2019

\$2

Designed & Printed by



Shark Bay Inscription Post

DENTAL HEALTH SERVICES

Will be located at the
SHARK BAY SCHOOL

Mob: 0447 854 272

Wednesday 3rd to Wednesday 25th September 2019

Wednesday 16th October to Wednesday 6th November 2019

Wednesday 27th November to Wednesday 11th December 2019

See
inside
pages for
details

THE FAMILY OF

Nellie Cock

INVITES YOU TO SHARE A
CELEBRATION OF HER LIFE

DOVE

Live at
**THE
HERITAGE
RESORT**

Wednesday
October 2nd

6:30 - 9:30pm



AFL GRAND FINAL

SATURDAY SEP 28TH

LIVE MUSIC AFTER THE GRAND FINAL

featuring **MIKAYLA J**

THURSDAY 5 SEPTEMBER | 5PM - 6:30PM

LIFE DRAWING DRAWING FROM LIFE

Shark Bay Arts Council life drawing
group

Sunday 8th September 2019

GASCOYNE SERIES

28TH & 29TH SEPTEMBER 2019



**Shark
Bay
Men's
Shed**

**Mondays
at 10am**

("the Shed" corner of corner of
Capewell Drive & Hoult Street)

Shark Bay



Club

**Monday and Friday
at 1pm**

at the Denham Town Hall
(corner of Hughes & Durlacher Streets)



**Every Tuesday
1:30-3:30pm**

at the Denham Town Hall
(corner of Hughes & Durlacher Streets)

Denham Seniors
JOIN IN FOR A CUPPA!



**Every Wednesday
morning at 10am**

at the Denham Town Hall
(corner of Hughes & Durlacher Streets)



The Ordinary Council meetings for 2019 will be held in Council Chambers, Shark Bay Recreation Centre, Francis Street Denham.

Wed 25 September
 Wed 30 October
 Wed 27 November
 Tue 17 December

Become a member of the Shark Bay CRC



ANNUAL MEMBERSHIP COST

(PRO RATA)

Monthly	\$20
Annual	\$50
Concession	\$30
Clubs	\$50
Businesses	\$100



Free internet

Discounted printing

Free DVDs*

(*) A member is allowed to borrow a maximum of 7 (Seven) DVDs per week. These DVDs are for PRIVATE viewings ONLY.

AUSTRALIAN TOUR 2019

DENHAM

Shark Bay Caravan Park

featuring **MIKAYLA J**

THURSDAY 5 SEPTEMBER | 5PM - 6:30PM
 SHARK BAY CARAVAN PARK | DENHAM . WA

WWW.MIKAYLAJMUSIC.COM



It is proven that walking improves your general health and well being!

Walking with friends is more fun!

Why don't you join our group & come for a walk?

It's free, it's fun, it's good for you!



Tuesdays @ 5pm

Meeting point: SB CRC

10 Denham road



Proudly supported by
 Australian Government

Shark Bay
 Community Resources
 & Centre
 Your local connection

Queensland Government



Food Sensations

Over the past month, Shark Bay CRC has hosted 4 Foodbank sessions via video conference where people can learn a variety of nutrition topics such as money saving tips, food label reading, takeaway vs homemade and planning healthy meals.

As part of each session, the group was able to cook some tasty, quick and easy recipes. Participants have enjoyed making rice paper rolls, a berry nice cheesecake, gnocchi, flat bread, creamless carbonara, fruity frypan cake, ready egg bake, and a dreamy date bake.

A big thank you to Julie Robins for helping us out for the first session - those cheesecakes were awesome too!

Natt

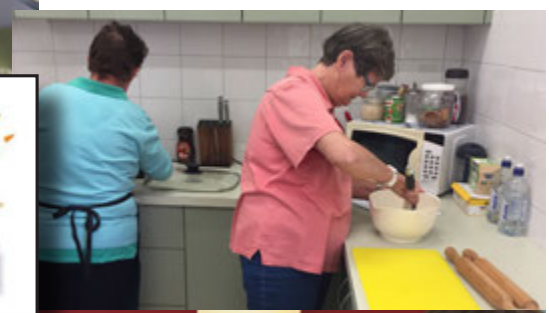



ATTENTION ALL **DOGS!**

Remind your human that Dog registrations are due 31 October.

Fees	1yr	3yr	LIFE
UNSTERILISED	\$50	\$120	\$250
STERILISED	\$20	\$42.50	\$100

Pensioners receive 50% off the above fees upon presentation of card.

It may have come to your attention recently, that the Ranger has been visiting individuals regarding their dogs.

Responsibilities come with dog ownership and we would like to further assist you in understanding some of those responsibilities.

As a dog owner are you able to answer yes to all these questions?

- **Registration:** Is your dog registered? All dogs aged three months and over must be registered with your local authority. Failure to register your dog may result in a \$200 on-the-spot infringement.
- **Tags:** Is your dog wearing a current registration tag?
- **Microchipped:** Is your dog microchipped with your current address and relevant contact information? All registered dogs must be microchipped.
- **Escape:** Are your fences and gates good enough to stop your dog going under, over or through them?
- **Behaviour:** Does your dog socialise well with other dogs and people?
- **Poo Patrol:** Do you pick up your dog's poo when it does its business in public?
- **Exercise:** When you are out and about do you have your dog on a leash in public or under your control in dog exercise areas?
- **Health:** Is your dog free of parasites and in good condition for its age/breed?
- **Home:** Does your dog always have sufficient shelter, cooling, water, food and attention?

Irresponsible dog owners may face significant penalties under the Dog Act 1976.

Please call the Shire of Shark Bay, 08 9948 1218 or contact the Ranger on 0418 531 485 for more information.

SHIRE PRESIDENT'S REPORT - AUGUST 2019



Passing of Nellie Cock

It was a sad day in the Bay when Nellie passed away recently. She was one of Shark Bay's unique characters. With her infectious laugh, love of life and cheeky comments, she has left us with some wonderful memories. On behalf of the Shire Council and local community, I extend heartfelt sympathy to her family and many friends. A celebration of Nellie's life will take place in the town hall on 6th September from 1pm.

Visit by Governor of WA

Shire Councillors, Shark Bay volunteers and community members extended a warm welcome to the Bay for His Excellency, the Hon. Kim Beazley, Governor of WA at a civic reception held at the Emergency Services Precinct earlier this week. Volunteers from a diverse range of local groups, including SES, SJA, VMR and Denham Fire Brigade attended the function, where the contribution that our awesome group of volunteers make to our community was acknowledged. These volunteers are an essential element in our local community and make the decision to freely give their time, energy and skills to enhance our enviable lifestyle.

It was the Governor's first visit to the Shark Bay area, so it was an opportunity to showcase many of our facilities and natural assets, including the Discovery Centre, Monkey Mia, Shell Beach, Hamelin Pool. I feel sure he'll be back soon to check out the rest of our attractions!

Art on the Move – Yagu Gurlbari – Big Secret

The Rose de Freycinet Gallery will be hosting this series of highly decorated and figurative artworks, with the opening night being held on Tuesday 3rd September commencing at 6pm. Everyone's invited to the official opening of the solo exhibition by a significant WA artist, Julie Dowling.

Rex Airlines Schedule changes

REX have now halved the advance time to book the Community Fare from 60 to 30 days, which should ensure that the lower fare becomes available to more travelers.

The 2019-20 Summer schedule for the Perth-Monkey Mia-Carnarvon route has recently been advised with a reduction of the number of flights during December – January when passenger demand is expected to decrease. On average there is a 30% reduction in passengers during January compared to the monthly average across the remainder of the year.

New Australian Citizens

I recently had the pleasure of performing an Australian citizenship ceremony for Fergal and Louise Troy who are residents of Monkey Mia, and congratulate them on their decision to formally become Australians and able to fully participate in the future of our community.

Cheryl

Cheryl Cowell
President

Activities	03 July	WA Local Government State Council meeting – Perth
	26	NAIDOC Celebrations – Yadgalah Aboriginal Corporation
	31	July Council meeting
		GDC Board induction – CEO Tym Donaldson
	05 August	Meeting - GDC Board Chairman – Andy Munro
	21	Gascoyne Development Commission Board meeting
	26	Civic Reception – Hon Kim Beazley, Governor of WA
	27	August Council meeting
		Australian citizenship ceremony



NELLIE COCKS

RETIREE

"I was born on the beach at Shark Bay; I was a twin but my sister died. My mother was Australian-Malay but we all used to mix together – white people and the coloured people – and we helped one another. We respected each other, too.

We'd picnic on the beach and the mothers and daughters would fish from the jetty while the boys went hunting for rabbit and different things. Sometimes the others would go out fishing on the boats although I wouldn't – I'm frightened of boats. We used to have horseraces on the beach. It was all so much fun.

I never had much schooling because I was a very delicate child. When I was sick, my mother would put me in the oven to keep me warm, like an incubator. The kids say to me, 'Nan, that's why you're so dark – you got burnt!'

My first job was on a station on Dirk Hartog Island. I learnt a lot of skills there, like waiting tables. The owners, Mr and Mrs McIntyre – she was a lovely lady – treated me like their own daughter.

I'm the only one left here from my family – my sister and brother passed away – but I've got plenty of grandkids down in Perth and Geraldton. Never mind, that's life. I'm alive, I don't drink, I don't smoke and I don't play cards anymore – we used to play rummy.

I'm at the age now where you just stay put. I've got a good girl who comes and helps me out and a lovely lady cleaner. I go down to the beach to talk to people every day. People are very good to me. I wouldn't live anywhere else." ●

"We'd picnic on the beach and the mothers and daughters would fish from the jetty while the boys went hunting for rabbit."



In loving tribute to Aunty Nellie Cock

In loving tribute to Aunty Nellie Cock at her passing on to glory. Shark Bay has lost one of our seemingly indestructible personalities, a real character, always welcoming and full of the joys of life, who everyone loved to see along Knight Terrace on her gopher in her latter years. It has been a privilege for us to know her and be her friend. We extend condolences to Howard and Iolanthe, Bec, Luke & Jarli, and all the rest of the family, and pray God's comfort in their loss and sadness.

Bill & Jocelyn Ross, and the members of St Andrews by the Sea.

"God will wipe away all tears from their eyes; and there will be no more death, nor crying, neither will there be any more pain: for the former things have passed away." Revelation 21: 4.



THE FAMILY OF

Nellie Cock

INVITES YOU TO SHARE A CELEBRATION OF HER LIFE

WE WILL GATHER FOR A FUNERAL SERVICE
AT THE TOWN HALL

6th SEPTEMBER @ 1pm

PLEASE BRING YOUR FAVOURITE MEMORIES ALONG



The deep Sadness we feel today is only matched by the Joy Aunty Nellie created wherever she was.
Thank you for your beautiful smile and the love you shared.
We miss you and express our sincere condolences to your family & friends
Patricia & Derek Weston

”
To live in the hearts
we leave behind is not
to die



*In Loving Memory of a Very Special Lady
"Aunty Nellie"*

*The Shark Bay Community Resource Centre Committee and Staff express their deepest sympathy on the passing of Aunty Nellie.
Nellie's infectious laughter, her kind heart and wonderful smiles will be sadly missed by us all.*

A beautiful Lady gone to heaven - Loving memories will always remain.

Our deepest sympathy to all her family and friends



Vincent Catania MLA

Member for North West Central

August 2019

Dear Shire of Shark Bay residents and visitors,

Permanent Doctor urgently required for Shire of Shark Bay

As your local Member of Parliament, representing and advocating on behalf of constituents in the electorate of North West Central, and after ongoing consultation with community members within the Shire of Shark Bay, I am again calling on the McGowan Labor Government to urgently instate the services of a permanent Doctor in Denham.

The need for a resident Doctor has been raised with me on numerous occasions and confirms some very valid reasons for calling on the State Government to instate a permanent Doctor in the Shark Bay region, such as:

- Providing medical services for the communities and hundreds of visitors to remote regions is essential.
- Ensuring the community is safe and the level of services available for the health and well-being of residents and visitors in the region is acceptable. With more than 6,000 tourism beds in the Shark Bay area, along with permanent residents, the number of potentially vulnerable people is significant.
- A reduction in waiting periods or long travel distances for both emergencies and simple requirements such as filling prescriptions or being medically assessed and treated in an appropriate timeframe without incurring additional costs, time off work and inconvenience.
- A reduction in stress levels placed on particularly vulnerable groups such as the elderly, families with young children and patients with severe medical conditions which may be time critical.
- Acceptable and expected levels of basic medical services to ensure new families, businesses and residents are attracted to live and visit the region.

How you can help me encourage the Government to instate a permanent Doctor in the Shire of Shark Bay

- ✓ Read and sign the attached Petition
- ✓ Return the signed Petition to PO 1000, Carnarvon, WA 6701 or deliver to the Shark Bay Shire office
- ✓ Like and share information in relation to this topic on my face book page – lets get the message out.
 - Facebook [VinceCataniaMP](#) - Twitter [@VincentCatania](#)

I ask for your support to continue the fight for this essential and vitally important community health service, to ensure basic medical needs are met with a permanent Doctor available to local residents and visitors in the Shire of Shark Bay.

I appreciate you taking the time to complete the petition and thank you for your support.

Yours sincerely,



Vince Catania MLA
Member for North West Central
Spokesperson for Transport; Tourism; Lands; Small Business; Veterans and Defence Issues
Industrial Relations



**Petitions
to sign
available
at the CRC**



Northwest@mp.wa.gov.au
www.vincecatania.com.au

[@VincentCatania](#)
[@VinceCataniaMP](#)

20 Robinson Street
(PO Box 1000)
Carnarvon WA 6701

Ph 08 9941 2999
Fax 08 9941 2000

What's Happening at The Oldie

Shark Bay Hotel

 Australia's Most Westerly Hotel



"The Old Pub" is truly the community's pub, come and cheer with the locals

We're open daily @ 10am
 Restaurant Open every day from
 12-2pm for Lunch & 6-9pm for Dinner,
 Coffee & cake all day,
 Only at the Shark Bay Hotel



Check us out on Trip Advisor

AWARDED:
 4 STAR CERTIFICATE FOR EXCELLENCE!

Visit the only hotel in the world where the original part of the building is made of Shell Blocks (tiny compressed cockle shells cut into building blocks from Shell Beach just out of Denham)

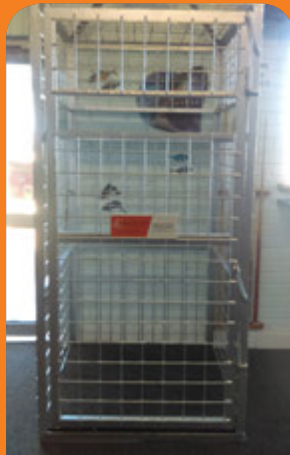

GET INSIDE A REAL SHARK CAGE

Tuesday
 Darts 7:30pm



Wednesday
 Local band
 'Parallel 26'

playing from 8.30pm
 karaoke & open mic



Friday
 Jag the Joker 5-7pm

Complimentary nibbles



Every Day 4.30 - 5.30pm

Pick a box
 \$5 middys, \$10 pints
 Cash jackpot \$500.00 to be won every day*,
 Everyone is a winner with prizes in every box!
 (*Every day apart from Friday between 4:30 & 5:30pm)

LUNCH SPECIALS
\$20

'BEST BAY BURGER DEAL'

Fish, chicken, hamburger or steak burger* & a midi of your choice (excluding spirits)

Available
12-2PM DAILY

*steakburger additional \$2

Local Artists

Studio & Gallery

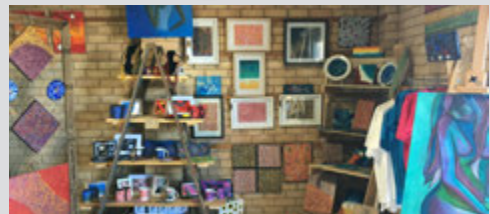

- Daily meal specials available
- Coffee & Cake @ \$9.50 per person available all day
- Icy cold beverages
- Accommodation available double & twin rooms
- Jukebox / TAB
- We cater to everyone's needs, just ask - *nothing is too hard*
- Available for catering and platters



Trading hours: open every day from 10am til late

Phone: 9948 1203
 www.sharkbayhotelwa.com.au
 enquiries@sharkbayhotelwa.com.au



Donations/Sponsors: A big thank you to the Shark Bay Bowling, Sport and Rec Club for donating all the roast meat for the school lunches fundraiser and all our sponsors for the recent Father's Day & Athletics Carnival raffles: Shark Bay Hotel, Denham Seaside Caravan Park, SB Fishing Club, Bryan Riddick, Heritage Resort, Surf n Dolphin, SB Speedway Club, SB Car Hire. Thanks also to SB CRC who donated Duplo to the Lego Club. We appreciate every little bit that comes our way. Thank you, thank you!

Father's Day Raffle:

1st – Lini Ironfield
2nd – Rick Moroney
3rd – Kerrie O'Neill
4th – Judy Britza

We made \$243.00 from this raffle which is a wonderful result. Thanks to everyone that purchased a ticket.

Lego Club: The Lego Club which now runs from the school library every Tuesday afternoon, has got off to a flying start with an array of amazing Lego creations. There are two sessions available 2:45-3:45 (Kindy to Yr 3) 3:45-4:45pm (Yr4 and up). Well done to Tish who has been busy running all these sessions. Please contact Tish if you would like your child/ren to participate in a session or if you can volunteer your time to assist her.

SUPPORT WANTED BRICK PROJECT: The Shark Bay P&C is working on a historical project by developing a "name/drawing" pathway, which will be installed alongside the Kindy/Pre-Primary entry/exit. We have extended the deadline for this so you still have time to submit your order.

Anyone is welcome to purchase a brick and you could include information such as your family name, business or community group name. All bricks order forms can be returned to the school front office. For further enquiries, please contact Jamie on 0427 272 560.

School Lunches: We hope you enjoyed the delicious school lunches we had recently. A huge thanks to Jamie and Sharna for coordinating this fundraiser and the helpers on the day: Yvonne, Jocelyn. If you would like to host your own school lunch fundraiser or are happy to assist for the next one please let a committee member know.

Father's Day Stall: This was very well received judging by the crowd that came through the Library doors to buy their Dad, Grandad, Uncles or even themselves a present for Father's Day. The keen shoppers could also get their gifts wrapped! Thank you to the gift wrappers-Tiaza and Jayda. Thanks also to Anne for helping with the masses and the Coordinator of this fabulous fundraiser - Jamie.

Save the Date: Next general meeting will be held in the School Library at 4:30pm on the 4th of September. All Welcome.

Thank you for your support,
Natt Dul – (President) On behalf of Shark Bay School P&C Executive Committee

Answer: Down.



YES!... Christmas is fast approaching and The Shark Bay Entertainers are soon to start their Christmas Carols rehearsals, for the famous Carols on Wheels' fifth year!

Bringing Carols fun and tradition to Shark Bay's residents and visitors.

May your joyous voice be heard!

To find out more, simply join us at our next meeting

**Thursday 19th Sept
5:30pm at the Shire Hall**

All ages welcome!



The Shark Bay Entertainers

**NEED
YOU**

**TO BE PART OF
THE CHRISTMAS
JOYOUS SOUNDS!**



Community Assistance Grants

Round 1 2019/2020

The Shire of Shark Bay invites local community groups to submit an application in Round 1 of the 2019/2020 Community Assistance Grants. Application form and guidelines are available on the Shire's Website or can be collected from the Shire Office. Applications received will be recommended to the October Ordinary Council Meeting and funding will be made available to successful applicants in November 2019.

Applications Open	Applications Close
Monday, 16 th September 2019	Friday, 4 th October 2019 (4pm)

Application criteria: equipment or minor projects for the value up to \$1,000

No late applications will be accepted

For more information please contact Candice, Community Development Officer on 9948 1218 or email cdo@sharkbay.wa.gov.au



**Shark Bay Men' Shed:
we meet every Monday at 10am
contact Kevin for details**

The Treasurer reported on a more healthy financial position, achieved by several generous donations from individuals & businesses in town, raffles, donations for a variety of projects in the community, and 3 nights catering for the Bowling Club Sunday Roast. This will stand us in good stead for the current application for a grant from Lotteries West to build our shed.

We are grateful again to the Shire Council for the allocation of a new block of land for the Men's Shed, in Hughes Street between the Pensioner

Shark Bay Community Men's Shed

The Men's Shed conducted its Annual General Meeting in August. It was pleasing to be able to fill all positions on the Committee, with some newcomers among them, as follows:

President: Kevin Laundry
 Vice President: Rob O'Brien
 Secretary: David Lergessner
 Treasurer: Geoff Howse
 Committee: Tony Shkardoon
 Nicko Brennan
 Bill Ross

Units and the Day Care Centre. This location enables us to build at a much reduced price and should guarantee our success with the Lotteries West Application.

The Men's Shed is always on the lookout for more men to join us, whether Denham residents or those on holiday for sunshine & fishing. We have a social get-together hour on Monday at 10.00am, at the temporary Shed at the top of the town on the corner of Capewell Drive & Houtt Street, where we are happy to welcome interested men & visitors.

Government of Western Australia
WA Country Health Service

Carnarvon Child Health Outreach

The Carnarvon Child Health Clinic welcomes you with support available for nutrition, development, immunisations, sleep & settling and parenting support

Community Health staff based at Carnarvon travel out to Denham and Useless Loop on the below date for 2019. To book an appointment call 9941 0500

1st August: Immunisation Clinic PM (by appointment only)
2nd August: Child Health Appointments (by appointment only)

15th August: Useless Loop AM (by appointment only)
 Denham PM (by appointment only)

19th September: Denham

10th October: Useless Loop AM (by appointment only)
 Denham PM (by appointment only)

14th November: Denham

5th December: Useless Loop AM (by appointment only)
 Denham PM (by appointment only)

Get in touch
 Telephone: 08 9941 0500
 Email: gcn@health.wa.gov.au
 www.wacountry.health.wa.gov.au

COMMUNITY | COMPASSION | QUALITY | INTEGRITY | JUSTICE HEALTHIER COUNTRY COMMUNITIES THROUGH PARTNERSHIPS AND INNOVATION

Government of Western Australia
North Metropolitan Health Service
Dental Health Services

Your ref
Our ref
Enquiries

DENTAL HEALTH SERVICES

Will be located at the
SHARK BAY SCHOOL
 Mob: 0447 854 272

Wednesday 3rd to Wednesday 25th September 2019
Wednesday 16th October to Wednesday 6th November 2019
Wednesday 27th November to Wednesday 11th December 2019

Dental Officer: Nadia Tedja
 Dental Clinic Assistant: Lisa Daw

Adult patients are requested to contact the Dental Clinic on its arrival to make an appointment.

If you have a current Health Care or Pension Concession Card issued from Centrelink you may be eligible for subsidised care. Please check with our staff at time of making appointment.

Payment is required at time of treatment. Eftpos cash or cheque accepted.

PROMOTING ORAL HEALTH & TEETH FOR LIFE
 Visiting Address: 43 Mt. Henry Road, Barber Park, Western Australia 6100
 Postal Address: Locked Bag 15, Thornbury Delivery Centre 6963
 Telephone: (08) 9313 0505 • Facsimile: (08) 9313 1902
 TTY: (08) 9313 2088 • AHP 61 282 636 952



For more information contact Femme Roberts
femmeeroberts@bigpond.com

LIFE DRAWING DRAWING FROM LIFE

Shark Bay Arts Council life drawing group

Come and join a casual group meeting once a month at the Art Shed (behind CRC),
Sunday afternoons from 3-5pm
to have fun and get creative with all things to do with drawing.

Think you can't draw—not a problem come anyway
Drawing from life covers figure, botanicals, still life and sketching outside—landscapes.
Refreshments supplied

Drawing dates

8th September
6th October
3rd November
(last day for the year)



\$2 per session

New members always welcome!

If you require more information
please contact Irene Marquis
0429 203 746



Shark Bay's Plumbing Service



PLUMBER - Brian Child

Licensed Plumber & Gas Fitter in the Bay.

All aspects of commercial and domestic plumbing and gas.

- Blocked Drains.
- HWU'S
- Backflow Prevention.
- RPZD Devices.
- Kitchen, bathroom, laundry renovations and refurbishments
- All aspects of roof plumbing.
- Building maintenance and repairs.
- No job too big or too small.

Don't risk it,
use a licensed plumber.

Call Brian today
0414 468 807

PL: 8146 GL: 015805

"SATISFACTION GUARANTEED
WITH A FRIENDLY,
PROFESSIONAL SERVICE"



plumovation@bigpond.com



Volunteer Marine Rescue

PO Box 35, Knight Tce Denham 6537 | vmrsharkbay@westnet.com.au



I am happy to report that there have been no calls for help to your local Marine Rescue Group in the past month. Well done to the boating public who must be keeping their boats and motors in good reliable condition.

Our members have been involved in training courses on the use of our WAERN radios and AIMS Awareness. AIMS is the Australian Inter-agency Incident Management System which is the ground rules for how VMR fits into the network of responders called upon in emergencies.

Our shed in Durlacher Street has had the concrete floor ground and painted by professional contractors and it looks brand new and will be much easier to keep clean.

We had a visit from the Australian Maritime Safety Authority's inspector who came to Denham to do surveys on commercial vessels. Both our vessels were up to the standard required to comply with their Certificate of Operation which was a good result.

A film crew from DFES Media came to Denham to make a short film about the successful rescue of a man and his two sons whose boat capsized and sank near Steep Point in April. The film will be shown as part of the awards night at the conference weekend in September.

Four of our members will be going to the conference weekend at the Perth Convention and

Exhibition Centre. The weekend showcases all the latest developments in Marine Rescue and features guest speakers and tours of Water Police HQ among other highlights.

In another exciting development we have successfully applied to DFES for funding to have a floating catwalk built and installed at our boat pen. This will be of great benefit to the boat crew and skippers who currently get onto the boat by clambering over the bow from the jetty. A catwalk will make it much safer and quicker to get onto the boat and the reduced response time could one day be the difference to the outcome of a critical incident.

There is always plenty happening with your local VMR Group, so if you want to get involved, call 99481376 and ask for a nomination form. Meanwhile, always keep boating safety in mind when heading out on the water.

Drew

VMR AGM

**Volunteer Marine Rescue's AGM
which will be held at
Sunday the 13th of October 3 pm
at the VMR shed in Durlacher Street.**

Local news from...
SHARK BAY POLICE STATION
Durlacher Street, Denham WA 6537



Find out what's happening in town.
What the word on the street is,
happenings and events at;
@SharkBayPol



St John Ambulance First Aid Kits FOR SALE

at the Shark Bay CRC
Prices vary \$30 - \$40





Shark Bay

Bowling, Sport and Recreation Club

ABN 35 876 340 257

PO Box 85
Denham WA 6537
Phone: 08 9948 1353
Email: SharkBayBowls@westnet.com.au

Shark Bay Annual Bowling Carnival

The Shark Bay Annual Bowling Carnival was held on the 3rd and 4th of August 2019. Fourteen teams, 56 participants, from all over WA with players from as far south as Augusta, Esperance, Dunsborough and Donnybrook as well as Kalgoorlie, Jurien Bay, Geraldton and Northampton and not to forget our local teams. The weather was great all weekend, no rain and no wind, the latter being very unusual for Shark Bay.

There was some fierce competition and after the first 3 games on day one there were 2 teams with 3 wins and 2 teams with 2 wins and a draw. On the second day after 5 games there was only 1 team (a Shark Bay local team) who had not lost a game yet and they had to play the last and deciding game and the team who would win that game would be crowned the winner.

After 11 ends the score was 10 all, with 3 ends to go, so it got very quiet on the green.

The local team lost the game though and their opponents from Northampton won the game and the carnival.

The final result was as follows:

1. Northampton: Vic Forrester, Norm Cowan, Pauline Forrester, Neville Simmonds, **10 pts +28**
2. Shark Bay / Dunsbrough: Di Fancote, Alison Beales, Barry Beales, Peter Fancote, **9 pts +34**
3. Shark Bay: Wilanda Bakker, Ian Dinsdale, John Miller, Johan Bakker, **9 pts +30**
4. Team Clifford (Donnybrook), **8 pts +17**

Wooden Spoon: Northampton; Graeme Conley, Eric Simkin, Kaye Simkin and Derek Parsons.

The Carnival weekend was a great success for our small community, and I would like to thank all volunteers who have been helping out at some time during the weekend.

Last but not least a huge thank you to all our sponsors.

Shark Bay Bowling, Sport and Recreation Club Bowling Carnival Sponsors 2019



Drennan O'Malley – Geraldton
Kalbarri Pestcontrol

Peter Mc Gabe – Donnybrook
Seaspray Beach Holiday park – Dongara
Tyrepower – Geraldton
Blue Lagoon Pearls – Denham

GJ Freight – Donnybrook
Wintersun Hotel – Geraldton

Mitchell & Brown / Retravison – Geraldton
Bunnings Warehouse – Geraldton
Shark Bay Hotel – Denham

Please support our generous sponsors!

St Andrew's by the Sea



Father's Day.

What makes a good father?

There was this well to do farmer who had two sons working the property with him. One day the younger boy came to his father and said, 'Hey dad, it's time I got to see a bit of the world. Do you reckon I could have what's coming to me now?'

With a heavy heart his dad gave in to his request and divided the property between the two brothers. Not long after the young boy packed his bags and took off on his travels.

He had the time of his life, spending his inheritance on a wild and lavish lifestyle. But in time he had wasted everything he had. About then the land was caught in the grip of a severe drought, and the boy found himself in dire need. All his so-called new friends deserted him,

and no one gave him anything. In desperation he got a job with a farmer who sent him to look after the pigs – a long way from his noble beginnings. By now he was so hungry he would have gladly eaten the corncobs in the pig slop.

That brought the miserable young man to his senses. He thought, 'Crikey, the farmhands back home sit down in the big house to three meals a day, and here I am starving to death in a pig sty! There's nothing for it but to go back and beg dad for help. I'll have to tell him I stuffed up. I don't deserve any favours; so I'll ask can I get a job on the farm.' And he set out to hitch hike the long road home.



But his father had never given up on him, & was always wondering how he was getting on. While he was still trudging up the farm drive, his father saw him. With heart pounding, the old man ran to meet his son; he greeted him with delight and

hugged him delightedly. Shame-faced the boy blurted out: 'Dad, I've let you down, & I've done wrong in God's eyes; I'm sorry; I don't deserve to be called your son.'

But his dad wasn't listening. He was calling to people in the house, 'Quick. Run a bath, get out a clean set of clothes and boots for him – those ones I've been keeping for a special occasion. He called to one of the farm hands to kill the heifer in the house paddock and put it in the oven. 'We're going to celebrate! My son has come home. I thought he was lost but he's not! It's like he was dead and now here he is alive!' What rejoicing there was in that household!

If you think that father was a bit over the top, let me assure you that's how our father God in heaven relates to us when one of us, his wayward children, come home to him.

Have a Happy Father's Day!

Bill Ross.

St Andrew's by the Sea
cnr Brockman & Hughes Sts
(Residence at rear)
Ph. 9948 1067 - M.0417 969 110



Find us on:
facebook

**Shark Bay
Shellblock
Church**



St Andrews by the Sea



Denham Seniors JOIN IN FOR A CUPPA!



Please come
along.
Have a cuppa
and
enjoy a chat.

We meet every
Wednesday morning at 10am
at the SB Shire Hall
(corner of Hughes & Durlacher Streets)

We welcome anyone 55yrs
and over to join our group.
Any visitors to Denham please
feel welcome to join us, even if you are
only passing through our town.

\$3
only
for a coffee
tea &
homemade
cake!



Coral Coast Dance Academy

www.coralcoastdanceacademy.com.au

Miss Amy's mobile: 0438 934 000

Email: info@coralcoastdanceacademy.com

Facebook: coral coast dance academy



This term we are working towards our concert dances and most classes have two items to dances to learn and perform in this year's concert. Our new acro mats have arrived. Katie and I have started teaching classes in Useless Loop.

ACRO MATS

From the fundraising money we have purchased and now using new acro mats. A roll out light weight mat for both classes and an air track mat for the senior acro students working on more advanced tricks.

POLO SHIRTS

Polo shirts have arrived and been handed out to those that ordered one. Thanks Sharna for organising them, they shirts look great and its good to see everyone wearing theirs to classes.

TERM 3 & 4

Term 3: Monday 22nd July – Friday 27th September

Term 4: Monday 14th October – Saturday 30th November

Full dress rehearsal Friday 29th November

Dance concert Saturday 30th November

ATTENDANCE is a must: Please come to all classes or notify me if you (your child) is away and unable to attend dancing. If they are injured, tired or feeling unwell please come and watch the class or stand in their positions as it is difficult for the rest of the class to practise when others are away and have to re go over practise they have already done when someone is away and has to catch up.

COSTUMES

Please see costume information document. **Costume payment is due 27/09/2019.**

Most students will have at least two costumes this year and some students will have four or more costumes. If your child does dance classes Monday and acrobatics on

Wednesday, then there will be four costumes so please expect to pay a total of around \$110 for the four costumes.

Unfortunately, as I am still waiting on at least two parents' payments for 2018 dance fees and costumes, so this year your child's costume will not be ordered until complete payment is made, and they cannot participate in the concert until all fees are paid.

Dance concert is Saturday 30th November 2019 Denham Town Hall 5:30pm.

CONCERT Saturday 30th November at the Denham Town Hall. Full dress rehearsal is Friday 29th at the Denham town hall. If you are able to help during the concert backstage/ dressing room, please let me know. Tickets will go on sale soon; it is highly recommended that you purchase your ticket when they go on sale as last year tickets sold out and there were no door entries available. Please make sure you have purchased your concert ticket this year. Tickets will include catering for after the concert wind up party on the night.

REMINDER no bullying will be tolerated in classes, please remind your child to be respectful, friendly, encouraging, team player with good sportsmanship during classes and concert. Students are at various skills and abilities in each class and we want to support and help each other learn, improve and celebrate achievements. If there are any issues in classes, please speak to me. Please remember to back their water bottle and take home their belongings after class.

Miss Amy

proudly supported by Shark Bay Shire



Miles of Smiles

Homework club at Miles of Smiles Family Day Care
 Yes, that's right! Now your child(ren) can be signed in for after school care + homework club!
 When: Mondays and Tuesdays
 Time: 2:30pm-5:30pm (minimum booking of 2hrs)
 Price: \$15 p/h (Centrelink rebate applies)
 Schedule:
 2:30-3pm - School pick up
 3-3:30pm - Afternoon tea
 3:30-4:30 - Homework club
 4:30-5:30 - Free play
 For more information please contact me (Gabi) on 0406 277 965 or send me an email to annagabiela@gmail.com
 Cheers

Costume Information

Full Costume payment due not later than the 27th of September

Preferred payment method is transfer

Account name: Coral Coast Dance Academy

BSB 086-643

Acc. 78-649-3811

Reference: your child's name

Please note if you have not paid your full term fees and costume payment by 27th of September your child can not participate in the concert.

Please speak to me if you need to make an alternative arrangement to pay.

I have tried extremely hard to find appropriate costumes at reasonable prizes and I hope you like them and your child feels special on stage performing.

Costume selection: The costumes in images in this document may change in colour, style or in any other way as availability could change from the time of printing to ordering. I will endeavour to keep prices and the costumes shown here as close as possible when ordering.

Costume sizes: Over the next few weeks I will be measuring the students for sizing in the costume orders. Please let me know if you would prefer to take the measurements, select the size or want larger size then measurements correspond to when ordered (i.e. you think your child will grow and be a bigger size between now and the concert).

Costumes take about 8-12 weeks to arrive from when ordered. When you receive the costume please get your child to try it on as soon as possible and notify me of any issues. Please label tags & accessories with their name and hang safely until the concert, do not wear to general dance classes or any other time, please keep it safe for the concert.

Please contact me if you have any questions. Miss Amy 0438934000
info@coralcoastdanceacademy.com.au or on Facebook



Happy Birthday in September

- 1 Joan Kovich
- 2 Terry Cowell
- 2 Mathias Cross
- 4 Garth Chamberlain
- 6 Phil Thomson
- 12 Laura Tomlinson
- 13 Dave Harrower
- 13 Whopper (Ray) Kevill
- 14 Frankie Hoult
- 16 Savannah Francis
- 17 Tianna Oakley
- 20 Kelvin Francis
- 20 Brian Child
- 24 Tara Fullston
- 26 Jackson Balcombe
- 27 Brian Galvin
- 27 Wolfgang Gentsch
- 28 Rebecca Stanley

Thankyou

A big thankyou to the kind person who picked up my harness & lead (when it fell off the top of the car) & returned it to our front yard.

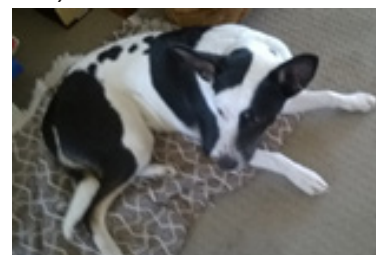

Patch.



How to check in on someone

Helping others and providing support can make a difference for someone who is having problems and going through a tough time. If you think someone you care about isn't going so well, try the following tips on how to support them and continue to check in on them.



Talk

For most people, just asking if they are okay and listening can make a difference.

By simply being there for someone, they can feel less alone and more supported to open up and talk about how they are really feeling.

Asking open ended questions that require a response is a good way to start the conversation.

FOR EXAMPLE:

- How are you going? What's been happening in your life lately?
- You don't seem quite yourself lately, is something bothering you?
- You seem upset or worried, what's going on? Can I help with something?
- I've noticed you're not going out much lately, anything going on?



Listen

Just being there for someone and offering a listening ear can make a difference.

1. Show them that you care and are here to listen to them.
2. Have patience, let others talk and don't judge.
3. Be reflective by repeating what they have said.
4. Keep calm and accept that they may disagree with you.



Provide support

If the person you're concerned about is in a life threatening situation, or is at risk of harm to themselves or others, call 000.

Getting help early can make a difference. A good place to start is:

- Talk to your GP or someone you trust.
- Call a support line.
- Contact a support service.
- Try the Think Mental Health check-up tool.

They may also need your support while they look for professional help.



Do an activity together

Activities create conversation. Find an opportunity during everyday life activities to start the conversation and ask them how they are really feeling. Try doing activities together such as:



GOING FOR A WALK



GOING TO AN EVENT TOGETHER



GOING FOR A COFFEE OR A MEAL



KICKING THE FOOTY, PLAYING A GAME, SURFING ETC

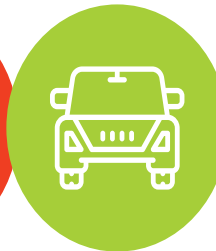

GOING FOR A DRIVE

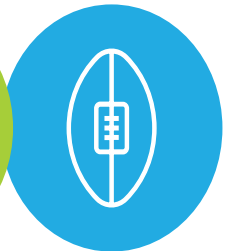

ANYTHING THAT ENCOURAGES OR PROVIDES AN OPPORTUNITY TO HAVE A CHAT

think
MENTAL HEALTH

For more information visit
thinkmentalhealthwa.com.au



Be Connected

Get Online Week 2019

Come and join us for an interactive colour by number fun session on our brand new ipads, whilst enjoying a FREE BBQ Lunch.

Who: Everyone is invited, Bring a friend and come along 😊

Location: Shark Bay Community Resource Centre

Date: Monday 14th October 2019

Time: 11:30am – 2:30pm



What: Ipad session includes colouring in by numbers and jigsaw puzzles

Free BBQ Lunch + Soft Drinks Provided



If you have your own Ipad or similar device, please bring it along too



Be Connected
Every Australian online.

Network Partners

Raising awareness of digital technology

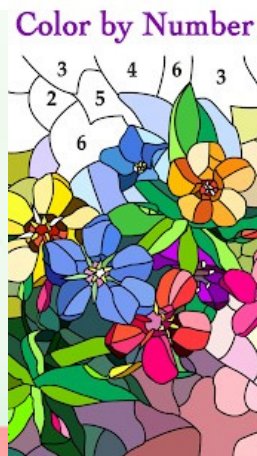
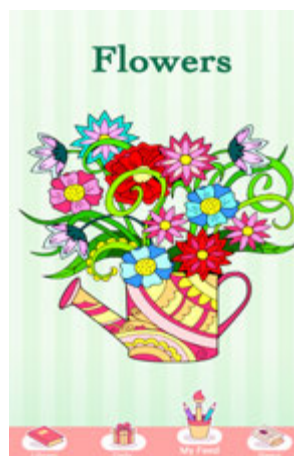
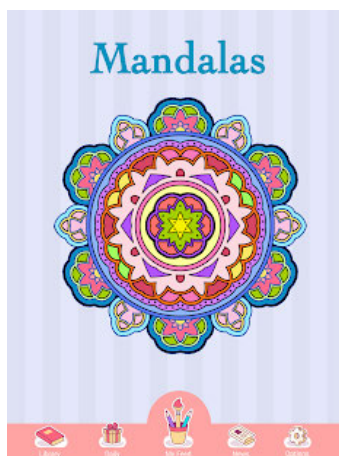

GASCOYNE SERIES

28TH & 29TH SEPTEMBER 2019



PHIL WOOD
0427 080 063
24 Hour Call
Marine Electronics
and Communications
Radio's Sounders, Radar,
Solar & DC Power
Boat Care

DAY 1 - 28TH SEPTEMBER 2019 - RACING FROM 11AM
MODIFIED PERPETUAL & JUNIOR PERPETUAL PLUS STREET
STOCK, PRODUCTIONS, WINGLESS, SPRINTERS & SUPERMODS

**WEEKEND
OF FUN!**

**CATCH YA
ON CLAY AT**



CARNARVON SPEEDWAY

NIGHT 2 - 29TH SEPTEMBER 2019 - RACING FROM 6PM
MODIFIED PERPETUAL PLUS JUNIOR SEDANS, STREET STOCK,
PRODUCTIONS, WINGLESS, LIMITED SPRINTS & SUPERMODS



NOMINATIONS NOW OPEN
Nominate via each club and visit club
Facebook pages for Event details.

Image Credit: Beau Toa Photography



Gascoyne
Chiropractic

Gascoyne Chiropractic is
visiting Denham at the
Community Resource Centre

NEXT VISITS

MONDAY

2nd September 2019

To make an appointment
please call 9941 1490



**Have your say
on the future
of road safety**

IMAGINEZERO.RSC.WA.GOV.AU

IMAGINE
ZERO



**Speedway
Shirts
now \$25
at the CRC
Kid's Shirts \$20**



Applications are now open for the second round of our
Regional Economic Development (RED) Grants Program.

Up to \$250,000 is available for individual projects that promote sustainable jobs,
partnerships, productivity, skills and capability, as well as stimulate new investment
in industry diversification.

The first round of investments totalled \$6.38 million in
70 projects for initiatives including tourism expansion,
Aboriginal training, new industry development and
agricultural diversification.

Find out more at gdc.wa.gov.au/grant-schemes/red



St John

ST JOHN AMBULANCE SHARK BAY

**Full Day Course
from 8:30 am till 4:30pm**

“Provide First Aid”

HLTAID003 Provide First Aid

Wednesday 4th September 2019

**Save a life
it could be that of a loved one!**

For all enquires and registration contact

Karen: 0428 930 407

saintjohns1@bigpond.com





Shark Bay School News

We've had a very satisfying first half of term at Shark Bay, with some whole school events, lots of community support and steady progress in all the classrooms.



Science Week

All the classrooms have been buzzing with Science activities in honour of Science week during week 4 of term. Rockets, landing craft, galaxy slime and moon sand were all big hits. Children and parents gathered to view the moon from the oval on 14th August, led by Mr Riddick.

Council, P&C and Community

A big thank you to our School Council and our P&C. Both committees have met this term to share their ideas for improving the school and supporting it. We had positive responses from our Suggestion Slip survey as well, with many ideas about things such as assemblies, incursions, senior sport and fundraisers so thank you for all the input, all of which is being carefully considered.

A key revised policy discussed with the Council, and with each and every student, is our Student Engagement Policy, which sets out our mutual expectations of rights and responsibilities for all members of our school community, based upon respect, responsibility and resilience.



One new initiative of the P&C this term is the after-school LEGO club, which got off to an enthusiastic start in week 4, with

children and family members of all ages enjoying the amazing kits. Special thanks to Tish Browne for running it.

The children have also been enjoying after school sport in preparation for the athletics carnivals and we appreciate Mr Reddick, Ms Barton and many parent helpers for helping and training the students.



The students ran a 'Red Nose Day' assembly on 9th August, in aid of SIDS and it was great to have

participation from Kindy to senior school; the costumes were fabulous. Thank you, Mrs Moroney, for all the enjoyable competitions and fundraising products. In total \$246 was raised for this worthy cause.



SIDE visits
We welcomed teachers from the School of Isolated and Distance Education

(SIDE) to visit during week 2 (Health and Social Sciences) and 4 (Maths and English). The combination of SIDE programs and small-group tutorials in school is a winning combination for our students.



ClassDojo

Class DOJO

If you have a child enrolled at Shark Bay School you should have received an invitation via the email address or phone registered with us and we invite you to accept the invitation and follow the prompts to join the system to enjoy small news items, photos and videos of your children and to facilitate communication with school. Come and see us if you have any queries about it.

Reading and Writing

Reading is one of the most important ways to learn and to enjoy learning. At Shark Bay we aim to promote a love of reading in many ways. The Bookfair in week 3 was a beautiful display of tempting books – thank you, Mrs Feist – and a great many have gone home with happy new owners. As a result, we also received over \$350-worth of new books for our library. Reading at home with your children, or to them, or discussing books, is one of the best ways family members can support the learning of students of any age. We enjoyed a visit by author Steve Herron in week 4. His passion is to inspire hope in children, through children's literature and he gave workshops to inspire our junior and senior primary students. More information at <https://steveheron.com/>

Our students have started to contribute work to the Australian children's magazine Jetsetter and we are excitedly looking forward to seeing the first of their names in print. The magazine will be provided in pdf format to the school and family members will be welcome to come and view it on our ipads.

Enquiries or visitors welcome to the school at any time.

<https://myschool.edu.au/school/48507>
https://www.det.wa.edu.au/schoolsonline/overview.do?schoolID=5418&pageID=S001&resetSearchType=ONE_SCH

Coming up:

- Early Close 2pm 26/08,09/09, 23/09
- Fathers' Day Stall/Breakfast 29/8
- Faction Jumps/Throws 29/8
- Faction Carnival with Useless Loop 30/8 Interscholar Athletics 12-13/9
- Assembly/Open Classrooms 1.45pm 26/9

Shark Bay School - 55 Francis Road, Denham WA 6537 - Ph 9948 0000
Principal: Celia.Elissegaray@education.wa.edu.au

KEVIN LAUNDRY

twintub1@bigpond.com

0402 464 204

Additions
Renovations
Industrial
Unit developments
House plans

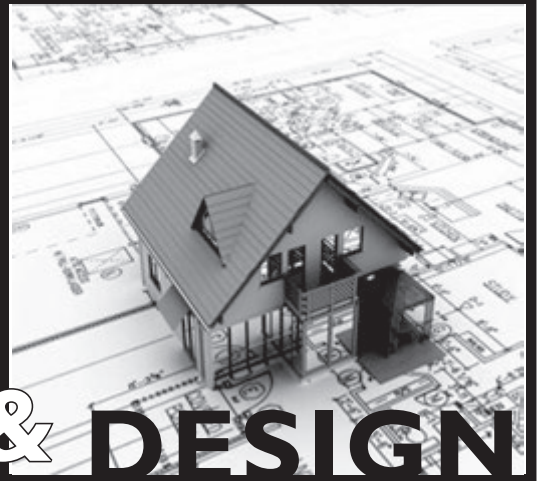

DRAFTING & DESIGN

It can be hard to know when you should seek help for a mental health issue.

A good place to start is to visit your GP!

Visit thinkmentalhealthwa.com.au



SES Shark Bay

Emergency Services Precinct, Dampier Rd
Denham WA 6537 sessharkbay@iinet.au

ring **132 500**
for SES emergency assistance



Geraldton's New SES Building

Judy attended the official opening of Geraldton's new SES Building. This building is situated near the airport and includes a training room, 3 offices, communication room, 3 bathrooms, kitchen and a storage room. They also have a very large shed that includes a large storage area for equipment, laundry room, staff room and 3 drive through bays for vehicles.

Honorable Minister Francis Logan from Department of Fire and Emergency Services officially opened the building. There was a large attendance of other Ministers and

Politicians, Media, SES members and the general Public.

Judy





The fun bunch of volunteers and trainers from Geraldton, Kalbarri, Shark Bay, Perth...

SES 4WD & Recovery Training at Its Very Best

It was a full-on four days of training with a knowledge base outcome that will linger for years to come.

Split into two parts – “driving” and “recovery”, we had a vast amount of knowledge and experience past onto us by a very experienced team of four; – Tim & Adrian being the team leaders, ably assisted by Steve & Hendrick of the Kalbarri SES headquarters.

The alarm-clock went off at 6am, breakfast was at 7am and theory training started at 8am.



Assessing the situation



Ado demonstrating the Kangaroo jack!



“Resting the Gearbox on a rock”



Stuck in the mud, getting the winch set up



“It’s all about balance”



“Resting” the front axel on sand



Crawling down the hill



Car wash after the exercises



Car wash “firies style”



Backwards the steep rolling hill



Convoy ready for action

After lunch, hands-on practical training began in some of the most amazing terrain WA has to offer. We had it all, mud, floods, rocks and sand, the only thing missing was snow and ice.

We were taught how to handle a 4WD vehicle properly, ie what to do and more importantly what not to do. We found out what a 4WD is really capable of and their limitations. Even how to "load the vehicle" to minimise the risk of "overturning".

Now, while it was all serious stuff, we had plenty of time for some great laughter and fun which made this whole weekend a really great experience.

There is so much valuable knowledge to be gained within the SES – ranging from radio operations, vertical rescue, supply logistics and much, much more. You don't have to be super fit to belong and to be of benefit in an emergency situation.

*Derek
& Patricia*



Getting stuck in sand dunes and practice the use of track mats and/or Snatch Strap



"Oh no.. the tide is coming in...!"



The Spotter strategically guides the Driver



One must walk through the water to check for hidden obstacles before attempting crossing



Three point anchor for a safe recovery



Winching out of a muddy trap



Cars bogged on the beach left right & centre... keeping volunteers busy figuring out the best recovery techniques for each case.

For more information about SES, what we do, training opportunities, or just want to join, ring our Local Unit Leader Joe 0419 902 895 or the SES Duty Phone 0429 481 218

REMINDER

Training nights have been changed to the 1st and 3rd THURSDAY nights of each month. Starting at 5pm

2019/20 SES Committee

Local Unit Manager:

Joe McLaughlin
(this position is appointed by DFES)

Deputy Unit Manager:

Terry Roberts

Administration Officer:

Judy Britza

Membership & Media Officer:

Natt Dul

Social events Officers:

Derek & Patricia Weston

Precinct Maintenance Officer:

George Livesey

Equipment Officer:

Terry Roberts

Need a doctor when your local practice is closed?

Access to doctors after hours
and all public holidays by
phone or video in rural WA*

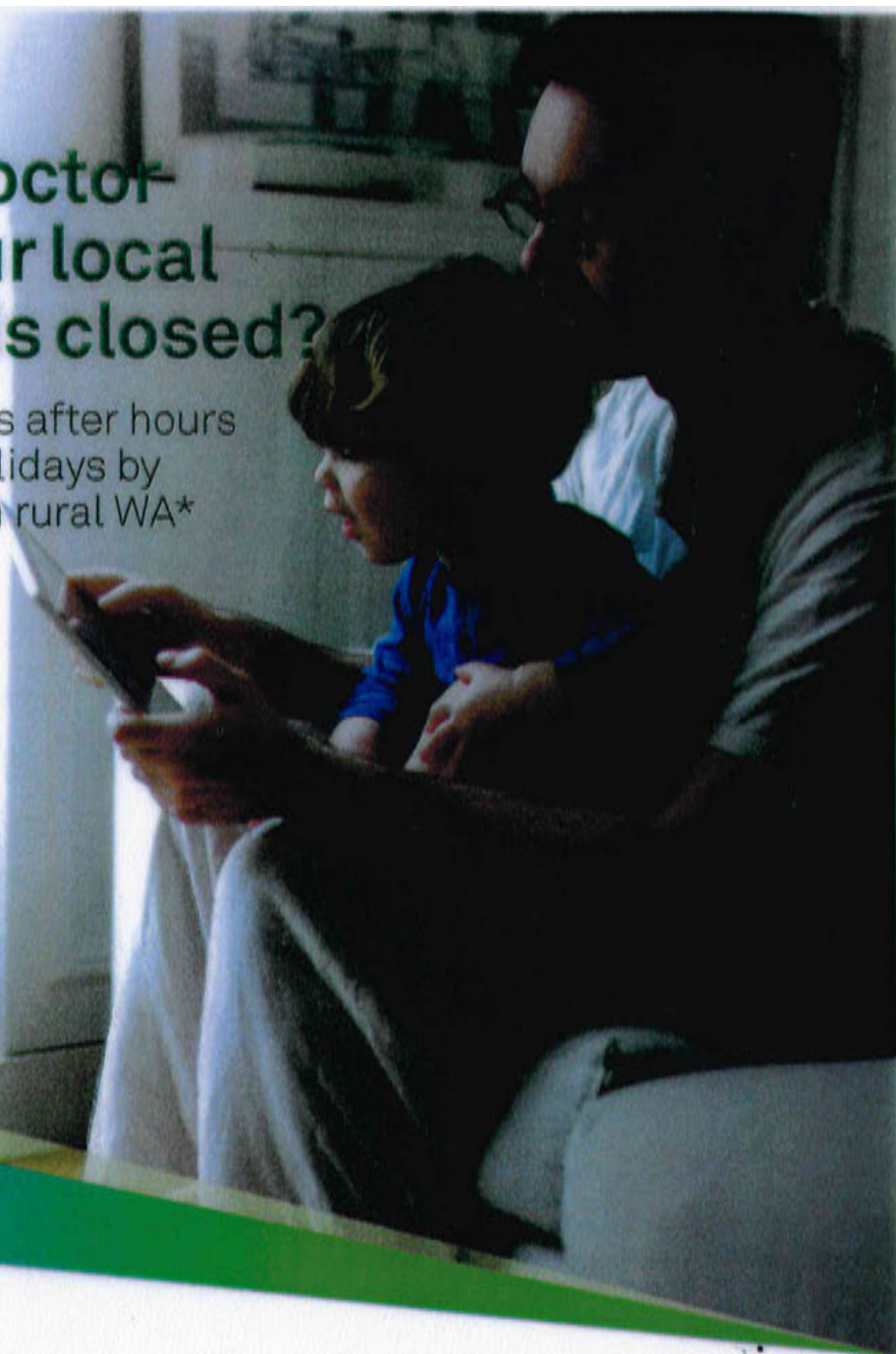

1800 CALL A DOC

Find out more

☎ 1800 CALL A DOC (1800 225 523)

🌐 1800calladoc.com.au

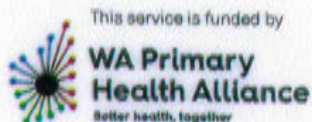

The CALL A DOC service has been made possible by WA Primary Health Alliance through funding provided by the Australian Government under the PHN Program.

* Available to specific postcodes in rural WA, to check your eligibility visit www.1800calladoc.com.au.

In case of emergency, call 000



Monday	2pm - 4.30pm 6.30pm	Courts open - @ Rec Centre Badminton - <i>adults only</i> @ Rec Centre
Tuesday	9.30am - 11.30am 2.30pm - 4.30pm 5.00pm - 6.00pm 6.30pm	Kindy Gym - @ Rec Centre Courts open - @ Rec Centre Walking group - @ CRC carpark Basketball - <i>adults only</i> @ Rec Centre
Wednesday	6.30pm	Indoor Soccer - <i>adults only</i> @ Rec Centre
Saturday	9am - 12pm	Courts open - @ Rec Centre



Equipment for popular ball games is available

**Basketball
Dodgeball
Netball**
OR OTHER BALL GAMES

Children under 7 years must be accompanied by an adult at all times in the Recreation Centre.

FEES APPLY TO PARTICIPATE IN THE FOLLOWING OTHER COMMUNITY ACTIVITIES

Mondays	4:30 - 5.00pm	Beginners combo dance/acro @ Town Hall, Coral Coast Dance
	5.00 - 5:30pm	Junior dance @ Town Hall, Coral Coast Dance
	5:30 - 6.00pm	Senior dance @ Town Hall, Coral Coast Dance
Tuesdays	4:30 - 5:30pm	Karate @ Town Hall, Samuari School of Shukokai Karate
Wednesdays	4:30 - 5:15pm	Junior acro @ Town Hall, Coral Coast Dance
	5:15 - 6pm	Senior acro @ Town Hall, Coral Coast Dance
	6.00 - 6:30pm	Tap @ Town Hall, Coral Coast Dance
Thursday	4:30 - 5:30pm	Karate @ Town Hall, Samuari School of Shukokai Karate
	6.00 - 7.00pm	Dodgeball @ Rec Centre, Shark Bay Youth Group

Classes now available in Useless Loop (contact Coral Coast Dance for dates and times)





Seth's fishing report



Sorry guys,

I haven't done any fishing this month. I have been real busy on the Xbox, but I promise I will have a great report for you next month!

I, along with the Shark Bay Fishing Club, wish to congratulate Bodhi Garner for winning August's Fishing Comp.

He got an awesome Pink Snapper weighing in at 4.510kg which was just heavier than Kathy Gibb's and my Uncle Brett's one.

Seth Burton
11 years old
Local junior Angler/Bay Boy



Want to know what's going on at the Shire?

- Road Closures
- Community Meetings
- Mosquito Fogging Program
- Rubbish Collections
- Community Events
- Rose Freycinet Gallery Displays
- Project Updates



Sign up to receive free

SMS Updates to your mobile phone

Please fill in the information below and hand in to the Shire office or email to reception@sharkbay.wa.gov.au

Name

Mobile Phone Number

Email Address



DENHAM – WESTERN AUSTRALIA

LAT 25° 56' S LONG 113° 32' E

Times and Heights of High and Low Waters

© Copyright Commonwealth of Australia 2018, Bureau of Meteorology
 Datum of Predictions is Lowest Astronomical Tide
 Times are in local standard time (Time Zone UTC +08:00)
 Moon Phase Symbols ● New Moon ○ First Quarter ○ Full Moon ● Last Quarter

SEPTEMBER

Time	m	Time	m
1 0203	0.93	16 0158	0.85
SU 0713	0.54	MO 0749	0.42
1348	1.20	MO 1413	0.95
2121	0.39	2041	0.42
2 0238	1.00	17 0219	0.90
0831	0.50	0840	0.40
MO 1437	1.13	TU 1444	0.93
2140	0.47	2053	0.47
3 0314	1.07	18 0241	0.94
0952	0.46	0932	0.39
TU 1526	1.03	WE 1517	0.90
2135	0.53	2107	0.52
4 0350	1.11	19 0303	0.98
1057	0.43	1023	0.39
WE 1613	0.91	TH 1552	0.86
2126	0.57	2117	0.57
5 0429	1.13	20 0324	1.02
1158	0.42	1113	0.39
TH 1705	0.79	FR 1633	0.80
2131	0.59	2119	0.62
6 0508	1.12	21 0347	1.05
1301	0.42	1205	0.39
FR 1804	0.69	SA 1725	0.75
● 2140	0.60	2122	0.65
7 0548	1.09	22 0423	1.08
1413	0.41	1304	0.40
SA 1937	0.62	SU 1837	0.69
2147	0.60	● 2121	0.66
8 0636	1.05	23 0513	1.10
1531	0.40	1420	0.41
SU MO			
9 0737	1.00	24 0617	1.09
1649	0.38	1556	0.40
MO TU			
10 0859	0.96	25 0740	1.08
1755	0.35	1715	0.38
TU WE			
11 1016	0.95	26 0926	1.07
1845	0.33	1812	0.37
WE TH		2350	0.78
12 0109	0.70	27 0424	0.66
0439	0.64	1055	1.09
TH 1121	0.95	FR 1857	0.38
1921	0.33		
13 0110	0.72	28 0014	0.85
0530	0.57	0536	0.55
FR 1214	0.96	SA 1202	1.10
1947	0.34	1932	0.42
14 0122	0.76	29 0046	0.93
0616	0.51	0644	0.45
SA 1300	0.97	SU 1258	1.09
○ 2008	0.36	● 2000	0.47
15 0138	0.80	30 0121	1.02
0701	0.46	0755	0.36
SU 1339	0.97	MO 1348	1.05
2026	0.38	2006	0.53

Tide Chart - Denham

NEW Fishing Fiesta shirts for sale at the CRC



\$30

Fishing Fiesta Shirts

over **30% off**



\$30

only at the CRC

Stubby Holders for Sale



\$9

SB Speedway

\$8

SB Fishing Club

DISTRESS FLARES



\$140

box of 4

On sale at the Shark Bay CRC

First Aid Kit Servicing

To assist Shark Bay businesses maintain their first aid kits, the Shark Bay Sub Centre now has access to the expertise and first aid stock of the Geraldton Career Centre.

This has increased the capacity of kit servicing and all proceeds of this service will remain with the Shark Bay Sub Centre for the benefit of your community.

Our comprehensive kit restocking service includes:

- ▶ Checking and replenish your first aid kits - at your workplace or with pre-arranged times at the location below.
- ▶ Sign the affixed compliance sticker on your first aid kit each visit.
- ▶ Provide ongoing support and reminders for when your next service is due.

Our kit servicing vehicle services business throughout the Midwest Region carrying a full range of quality assured and competitively priced products. For your convenience, we can visit you onsite and restock your first aid kits from as little as \$39.00.

To service first aid kits per location of your choice the following costs apply:

- ▶ *Fee to service up to 2 kits per location is \$39.00*
- ▶ *\$15.00 per additional kit.*
- ▶ *Kit components are charged per unit supplied / replaced.*

To service first aid kits at the location listed below the following costs apply:

- ▶ \$11.00 per kit
- ▶ *Kit components are charged per unit supplied / replaced.*



We also have a large range of First Aid Kits available for purchase. Make sure you are prepared for any situation with up to date first aid skills and a St John first aid kit.

Our first kits servicing opportunity at the Shark Bay Sub Centre will be:

25th September 2019

Please call now to book your kits in with us or drop them at the address below, before this date.
For more information or to book your kit servicing appointment contact us now.

Shark Bay Community Resource Centre
10 Denham Road, Denham 6537
Ph. 9948 1787
E. sharkbay@crc.net.au
Open: Monday to Friday – 9.00am to 4.00pm

Shark Bay Sub Centre
Cnr Durlacher Street and Dampier Road Denham
Ph. 9948 3023
E. saintjohns1@bigpond
Open: Wednesday and Thursday 10.00am to 2.00pm

“The Occupational Health and Safety Regulations 1996” require an employer to provide adequate first aid facilities; this includes first aid kits, which should be clearly marked. The first aid kit should contain basic requirements and additional items appropriate to the workplace.

Employers should ensure at least one worker is appointed to be in charge of the first aid kit, the person should be responsible for making regular checks, replenishing supplies, maintaining the contents and ensuring the contents are within their ‘use by’ dates.

St John Ambulance Western Australia Ltd.

17 Eaton Place Wonthella Western Australia

Tel 08) 9938 0900 | Fax 08 9964 5219 | Email geraldton@stjohnambulance.com.au | ABN 55 028 468 715 | ACN 165 969 406

www.stjohnambulance.com.au

In Aug your local Ambo VOLUNTEERS responded to...: **13** 000 call outs Year to date: **124**

WHY PAY AMBULANCE MEMBERSHIP FEES?

St John Ambulance Shark Bay Sub Centre

 *Because it can save you a lot of money!*

Do you know that a basic ambulance call out from the Shark Bay Hotel to Silver Chain will cost you over \$500?

For Membership fees of just **\$73 per single and \$121 per family** you would be covered for all of these costs.

This amounts to a little more than \$1.40 per week for a single or 20 cents per day.

Most pensioners over 65 are covered (please check your eligibility). **It makes sense to pay St John Ambulance fee, doesn't it?** saintjohns1@bigpond.com

CRITICAL REMINDER

To ALL RESIDENTS and VISITORS

For any life threatening emergencies or serious crime/incidents the number to call is 000



In Shark Bay many people have a tendency to call the local agency direct or private phone numbers of volunteers when requiring urgent assistance. Please be aware, this does not make response faster. In fact it delays the response time of emergency services as a response team can not be dispatched until the central command centre has directed them to do so. So call 000, response will be faster.

When calling 000, it is also important to remember that the operator will ask you the following questions, which will aid them in assisting you as fast and efficiently as possible.

Service required: Police/Ambulance/Fire & Rescue
 Your name:
 Town & State you are calling from:
 Location (address) of the incident:
 Nature of the incident:





Midwest Sexual Assault Crisis Line

1800 016 789

Desert Blue Connect

Crisis support and advocacy available 24/7



Word Search

YELLOW	COLD	LEAF
PIE	CRISP	CHANGE
BROWN	AUTUMN	APPLE
RAKE	RED	TURKEY
ORANGE		

L E A F Y E Y P N
 Y O A Y E K L E C
 C R U E K A D N R
 E A T L R R L W I
 I N U L U T O O S
 P G M O T F C R P
 C E N W R E D B W
 E L P P A P M A J
 B C H A N G E Q K



CHINESE TAKEAWAY

FRIDAY NIGHTS FROM 5.30PM

Restaurant Hours

LUNCH - 12.00PM - 2.30PM

DINNER - 5.30PM - LATE

FULL MENU AVAILABLE LUNCH & DINNER

DOVE

Live at **THE
HERITAGE
RESORT**

**Wednesday
October 2nd**

6:30 - 9:30pm



AFL GRAND FINAL SATURDAY SEP 28TH

LIVE MUSIC AFTER THE GRAND FINAL

Bottlemart

express

Shark Bay Youth Group



sharkbayyouthgroup@outlook.com

0409 331 728 (Bec - Chairperson)

16 Youth committed to going without technologies for 40 Hours from 8pm Friday 23/8/19 to 12noon Sunday 25/8/19. Well done to; Vee Jay, Jennifer, Nicole, Laylah, Chloe, Indie, Kyle, Jacob, Loki, Brent, Storm, Tiah, Telliesha-Rose, Daniel-Ryan, Chloe and Kade. You are all AMAZING!

A BIG Thank you to our Parent Helpers; Tegan, Donnelle, Sam & Amanda and to Shark Bay School for allowing us to use the facilities.

Youth not only had to go without TECHNOLOGIES for 40 hours but also had to earn and prepare ALL of their food.

Some of the challenges included challenging each other, a memory game, obstacle courses to keep their pillows, eating baby food and strange tasting lollies, passing an orange around under their neck with NO hands, building a sandcastle village, paper scissors rock championships, crossing the monkey bars as a team and getting the soccer ball to the other side whilst in a bubble ball!

Our youth have proven they are all very capable in the kitchen; Vee Jay is the KING of scrambled eggs, Kyle gets his fried eggs perfect every time, Indie and Loki rocked the BBQ - cooking some delicious sausages and bacon and Jennifer & Nicole smashed out some donut muffins and chocolate caramel brownies in no time. They certainly didn't go hungry!

It was a great weekend with lots of fun had by all...



Shark Bay Youth Group



sharkbayyouthgroup@outlook.com

0409 331 728 (Bec - Chairperson)

Shark Bay Youth Group Youth and Committee would like to sincerely thank everyone who came to our Quiz Night on Friday 16th August.

A BIG Thank you to all our Sponsors;

Shark Bay Bowling, Sport & Rec Club

RAC Monkey Mia (winner of our Sponsors Draw!)

Oceanside Village

Shark Bay Supermarket

Shark Bay True Value Hardware

CDH Electrical

Shark Bay Hotel

Yadgalah Aboriginal Corporation

Bunnings Geraldton

Mitchell & Brown Retravision

Bryan Riddick

Graham Egan

Reel Force Charters

On the Deck Shark Bay

Ray White Shark Bay

Congratulations to our winners:

Table 6 - Jamie Burton, Shaun Burton, Stacey Reynolds, Mick Reynolds, Anne Feist & Travis Feist.

Silent Auction Dockers Jacket - Caroline Baldwin

Sunset Cruise Raffle - Stacey Reynolds

Raffle Wheel 1 & 2- Valeri Mackie , a VERY lucky lady who won both Raffle Wheels!

Youth Tradie Auction Winners - Stacey Reynolds, Celia Elissegaray, Andrea, Claire Cooper & Peter Llewellyn.

Well done to our youth; Tom Moroney, VeeJay Court, Jennifer Moroney, Nicole Moroney, Chloe Rawlings, Chloe Harken, Lachlan Hannibal, Loki Mansen, Rane Mansen, Jacob Carlson, Laylah Garner, Tiah Dobney, Storm Marsh & Kyle Dobney.

Thanks to Amanda Dobney for scoring and to our Quiz Master Rick Moroney. Great Questions!

It was a great night and we raised \$1000.00

All money raised will be used to provide programs for our youth that enhance life skills and self-image, create opportunities for them to develop as individuals and learn and enjoy new challenges that will develop their sense of citizenship.





Department of
Transport

Safety Equipment Flares Marine Safety



Know how to use them

Flares are best used when you believe there is chance of it being seen.

The method used to fire flares varies widely between flare types and manufacturers. The firing instructions are always printed on the flare, and you should be familiar with your flare's method. Hand-held red flares, especially, burn very hot and may spill glowing embers. Hold it downwind so that embers don't spill into the vessel and point it downwards while in your hand to avoid being burnt.

If you see a flare, contact the Water Police or phone 000 to report it.

Storage

Flares should always be readily accessible:

- stored in a waterproof container (marked with the registration number of your boat);
- in a place where they don't receive too much pounding in rough conditions;
- away from dampness; and
- away from heat sources above 60°C.



Expiry dates

Flares must be within the expiry date and maintained in serviceable condition at all times. Check them regularly to ensure they have not been rendered unserviceable by exposure to moisture. Mildew or bubbling of paper coatings may indicate this.



Disposal

Do not discard unserviceable or out of date flares in general rubbish collections or land fill. Visit the DoT website for disposal locations.

Unauthorised use of flares

There are severe penalties for the improper use of flares. Flares have a very serious purpose.

Falsely indicating distress rightly carries a severe penalty, but it also wastes a lot of time and resources – possibly weakening the ability to respond to a genuine emergency.

Do not leave flares in your vessel when it is not in use, and keep them away from children.

Contact details

Email: marine.safety@transport.wa.gov.au
Website: www.transport.wa.gov.au/marine
Marine Safety Hotline: 1300 863 308

Police

Water Police: 9442 8600
Emergency: 000

Regional

Albany: 9892 7333
Broome: 9192 0200
Bunbury: 9792 6666
Carnarvon: 9941 6800
Esperance: 9076 2100
Exmouth: 9949 2079
Geraldton: 9956 0111
Kalgoorlie: 9022 5999
Karratha: 6551 6800
Kununurra: 9168 3298

For further information go to www.transport.wa.gov.au/flares or scan the QR code.



Join us at
facebook.com/MarineSafetyWA

The information contained in this publication is provided in good faith and believed to be accurate at time of publication. The State shall in no way be liable for any loss sustained or incurred by anyone relying on the information.



Distress flares

All vessels operating outside protected waters must carry flares. The type you need depends on how far offshore you travel. Flares must be manufactured to *Australian Standard AS 2092-2004* or comply with *Australian Maritime Safety Authority Marine Orders Part 25*.

For inshore waters

- Within five nautical miles from the mainland, or within one nautical mile from an island situated more than five nautical miles from the mainland, you will need:
- two hand-held orange smoke flares or one orange smoke canister; and
 - two hand-held red flares or two parachute flares.

For offshore waters

More than five nautical miles from the mainland, or more than one nautical mile from an island situated more than five nautical miles from the mainland, you will need:

- two hand-held orange smoke flares or one orange smoke canister; and
 - two parachute flares.
- If you operate both inshore and offshore you only need to carry an offshore set of flares.

Required flares

All boats operating outside protected waters must carry flares. The type you need depends on how far offshore you travel.

Distance from shore	Smoke flares	Incandescent flares
Inshore	2 hand-held orange smoke flares or 1 orange smoke canister	2 hand-held red flares or 2 parachute flares
Offshore	2 hand-held orange smoke flares or 1 orange smoke canister	2 parachute flares

Only an offshore set of flares is required if operating in both inshore and offshore areas.

Types of flares

Orange smoke flares



These are designed for day use only and have no luminosity. They emit a cloud of orange smoke. Orange hand held flares burn for about 60 seconds. The buoyant canister, which is safe for use in petrol or oil covered water, burns for about three minutes. Potential sighting range by day is 4 kilometres, although this can drop to less than 1 kilometre in a fresh breeze. These flares are especially visible from aircraft, even on windy days.

Red hand-held flares



These are designed for use both night and day and burn for about 45 seconds at 15,000 candle power. Potential sighting range at night is 10–12 kilometres and about 4–6 kilometres during the day.

Parachute flares

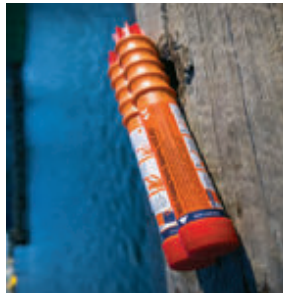

These are designed for use both night and day. They project a rocket to 300 metres high and then deploy a parachute-suspended red flare, which burns for about 40 seconds at 30,000 candle power. Potential sighting range is 15 kilometres by day and 40 kilometres at night.

Flares and their characteristics

Type of flare	Suitable use	Burn time	Sighting range potential
Smoke flares	Orange hand-held smoke flare	60 seconds	Day: 4 km Note: less than 1 km in a fresh breeze
	Orange smoke canister flare	3 minutes	Day: 4 km Note: less than 1 km in a fresh breeze
Incandescent flares	Red hand-held flares	45 seconds	Day: 4-6 km Night: 10-12 km
	Parachute flares	40 seconds	Day: 15 km Night: 40 km

Denham Community Groups

Community groups	Contact Name	Telephone No.
Boolbardie Country Club	Jill Deschamp	0477 245 309
Crisis Centre	Tim & Maggie Hargreaves	9948 1338 0429 481 338
Denham Community Church	Mark Sewell	0427 481 719
Denham Crafters	Shirley Geraty Irene Marquis	9948 3016
Denham Volunteer Fire and Rescue	Dave Harrower	Call 000 for Emergency Info ONLY: 9948 3289
Denham Seniors	Shirley Geraty Annette Dix	0409 208 862 0403 710 860
Family Day Care	Chelsea Griffith	
Karate (Shukokai)	Janine Standen	9948 3595
Kindy Gym	Natalie Dul	9948 1787
Shark Bay Arts Council	Claire Cooper	0415 612 621
Shark Bay Bowling, Sport & Recreation Club	Barry Beales	0417 179 834
Shark Bay Bridge Club	Coralie Hill Johan Bakker	0497 001 533 0458 255 261
Shark Bay Christian Fellowship	Tim & Maggie Hargreaves	9948 1338 0429 481 338
Shark Bay Community Mens Shed	Kevin Laundry (President) David Lergessner (Secretary)	0402 464 204
Shark Bay Fishing Club - Fishing Fiesta	Jamie Burton	0427 272 560
Shark Bay P & C Association	Natt Dul	9948 1104
Shark Bay Pistol Club	Bruce Wade (President) Cheryl Cowell (Secretary)	9948 1448 0417 180 307
Shark Bay RSL	Barry Beales / Wayne Moroney	9948 1288
Shark Bay Speedway	Michael Reynolds	0419 961 819
Shark Bay State Emergency Service (SES)	Joe McLaughlin	Call 000 for Emergency Info ONLY: 9948 1360
Shark Bay Business Association Inc	Isobel Lockyer	www.experiencesharkbay.com
Shark Bay Volunteer Marine Rescue (VMR)	Drew Wassman	Call 000 for Emergency Info Only: 9948 1396
St Andrew-by-the-sea Anglican Church	Rev. Bill & Jocelyn Ross	9948 1067 / 0417 969 110
St John Ambulance - Shark Bay Sub Centre	Karen Gidley (Chairperson) Linda Sewell	Call 000 for Emergency Info ONLY: 0428 930 407
The Shark Bay Entertainers	John Senteneller	0400 625 138
The Shark Bay Youth Group	Rebecca Moroney	0409 331 728
Yadgalah Aboriginal Corp.	Debbie Bellottie	9948 1318
Yadgalah Community Markets	Debbie, Sherry & George	9948 1318 - Yadgalah office 9948 3324 - George & Sherry 0400 169 983

Email	Day(s)	Location
jilldeschamp@westnet.com.au	Wednesday & Saturdays	Golf Club, Monkey Mia Road
sharkbayherald@westnet.com.au	24/7	
denhamcommunitychurch@gmail.com	Sundays 9.30am	Recreation Centre
sgeraty@bigpond.com	Tuesdays 1.30pm - 3.30pm	Denham Shire Hall
denhamvfrs@bigpond.com	1 st , 2 nd , 3 rd Tuesday every Month	Dampier Road, Fire Station
twintub1@bigpond.com (Helen Laundry)	Wednesdays 10am	Denham Shire Hall
Chelseamaygriffith@gmail.com		29 Hughes Street
jstanden@westnet.com.au	Tuesdays & Thursdays	Denham Shire Hall
sharkbay@crc.net.au	Tuesday 9.30am (except school holidays)	Recreation Centre
	Meeting 1st Monday of every month at 5.30pm	Arts Shed - 10 Denham Road
sharkbaybowls@westnet.com.au	(Currently) open from Wednesday-Saturday	Bowling Club, Francis Street
coralie-hill@bigpond.com jowiba@gmail.com	Monday & Friday 1pm	Denham Shire Hall
sharkbayherald@westnet.com.au	Sunday	Foreshore about opposite the Interpretive Centre
twintub1@bigpond.com bill.ross@kisser.net.au	Monday 10am	Shed at the top of the town on the corner of Capewell Drive & Hoults Street
sharkbayfishingclub@hotmail.com	Fishing Fiesta 15-22 May 2020	
sharkbaypandc@hotmail.com	People can contact the School for meeting dates	School Library
brucewade@westnet.com.au chezza@westnet.com.au	Sundays	Pistol Club, Monkey Mia Road
sharkbaycleaningservice@gmail.com		
sharkbayspeedwayclub@outlook.com	Far Western Championship	13th July 2019
sessharkbay@inet.net.au	1 st , 2 nd and 3 rd Monday 5pm	Emergency Services Building Durlacher Street
sharkbaytourism02@gmail.com	1 st Tuesday of every month	Recreation Centre
vmrsharkbay@westnet.com.au	4 th Monday of every month	VMR building, Knight Terrace
jocelynclareross@gmail.com	Sunday 9am, Thursday 3pm	Anglican Church
saintjohns1@bigpond.com	See Inscription Post Calendar for office opening hours	Emergency Services Precinct Durlacher St
sharkbay.entertainers@gmail.com		Denham Shire Hall
sharkbayyouthgroup@outlook.com		
yadgalah1@bigpond.com	Monday - Friday	Francis Street
yadgalah1@bigpond.com	Sunday's during school holidays	Francis Street



STRAYA

CONTRACTING PTY LTD

Mini Excavator Hire

All concrete finishing works including

House & shed slabs, crossovers, patios, driveways, footpaths etc.
Normal, coloured & exposed concrete.

Call or email Vaughan for a quote today

0417 301 397

vbeavis82@gmail.com

SHARK BAY SKIPPER SERVICES

ABN: 92677622419

HERE TO HELP



Having come to Shark Bay in 2002 and enjoyed the beautiful waters it has to offer, I now wish to help others do the same. I am offering vessel cleaning services, mooring maintenance, vessel transfers Australia wide and private and commercial skipper services.

- Vessel Hull Cleaning
- Vessel Antifouling
- Vessel Maintenance
- Vessel Transfers
- Skipper Services Private/Commercial
- Mooring Maintenance

Ring Wayne on 0439 347 683
Email: moby@outlook.com.au



Shark Bay SUPERMARKET

Open 7 Days a Week 7AM - 7PM

Shark Bay Supermarket welcomes you to Denham, for all your **GROCERIES, FRESH FRUIT, VEG AND MEAT SUPPLIES.**

Wide range of variety items including **BAIT, FISHING & SNORKELLING EQUIPMENT, ICE, TELSTRA & OPTUS RECHARGE.**

Fresh Hot Coffee and Pies

Pensioner discount day: every Friday.

So call in at the top end of town for *friendly, helpful service with a smile.*

It is just part of the service



1 Knight terrace, Denham, WA, 6537
Phone: 08 9948 1351
Fax: 08 99481051
sharkbaysupermarket@westnet.com.au



DENHAM IGA Xpress

Open 7am to 7pm
7 days a week

The first stop for all your food, fuel, ice, bait and fishing requirements



See Rob & Kellee
97 Knight Terrace
Denham, Shark Bay
Ph: 9948 1147



Gary's Auto Electrics

**Air Conditioning &
Electrical Repairs to:**
Marine - Heavy & Light Vehicles - Farming
- Earthmoving

75gmac@gmail.com

0428 648 282

This space (1/8 page) can be yours
for **\$20/ month**



Architectural Designs and Drafting Solutions

Complete architectural and drafting service

Planning and Building licence applications

All stages offered from designs concepts to planning and
building submissions and liaisons with local councils

Competitive Rates

Over 15 years Architectural Experience
Specialising in Sea Container Designs

Contact

Leander Crickmay
(B.Arch. PG Dip Arch)

0408056277
levelsixarch@outlook.com

Metal Fabrication - Welding



Steel - Aluminium - Stainless Steel
Sheet Metal Fabrication
Guillotine & Bending
Steel and Aluminium Sales

John FAMLONGA
0417 924 742
68 Vlamingh Crescent

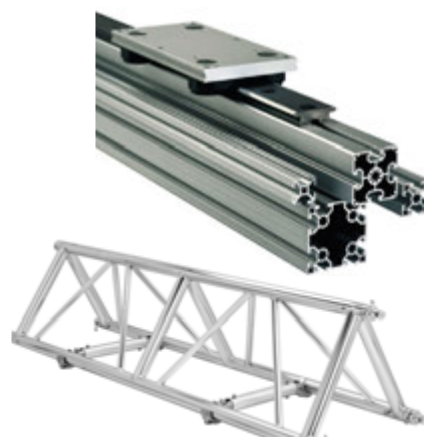

Batteries

- Vehicle
- Boat
- Caravan
- Camper
- Motorbike
- Heavy Duty Tonka Toys
- ...and more!



Shark Bay Services

Ph: 9948 1360
Joe: 0419 902 895
Judy: 0429 672 063

mcl@iinet.net.au
37 Vlamingh Crescent
Denham WA 6537

Ray White.

Shark Bay



Over 40
Self Contained
Holiday Homes
to choose from!

Ray White Sells & Rents

Rob & Trudy

71 Knight Terrace, Denham 6537 WA

P: 9948 1323 F: 9948 1020 E: sharkbay.wa@raywhite.com

www.sharkbayholidayhouses.com.au

71 KNIGHT TERRACE
DENHAM
WESTERN AUSTRALIA
(08) 9948 3429

Surf n Dolphin

FRIENDLY SERVICE

PRODUCTS FOR ALL AGES

OPEN 7 DAYS FROM 8AM

One Stop Shop

Ladie's, men's & children's clothing

Swim wear,

Thongs

Hats

Sunglasses

Beach Goods

Sporting Goods

Kids toys

Top Brands Surfwear

up to 50% Off
selected clothing!

USB flash drives

Souvenirs

Information

Australia made

Fishing shirts (50%UPF)

... and more

SHARK BAY HARLEY TOURS

YOU KNOW YOU WANT TO

Welcome to Shark Bay Harley Tours, where we conduct Harley Davidson motorbike tours - come for a ride and enjoy this amazing scenery with your own personal tour guide.

At Shark Bay Harley Tours we cater for the individual traveller looking for a unique experience. Are you looking for a little adventure on your holiday? Then come and enjoy the friendly service and share in our local knowledge of the area whilst getting to experience the wind in your hair on the back of a Harley Davidson.

So come on - lets get out on the open road in this pristine World Heritage Area on a Harley Davidson Motorcycle and enjoy what Shark Bay has to offer.

Tours:

1. Monkey Mia pickup to Denham and Ocean Park and return.

- Pick up Monkey Mia 9:30 am
- Denham for Coffee and sightseeing via Little Lagoon
- Ocean Park for tour and lunch
- Return to Monkey Mia
- \$245.00 (includes lunch and coffee)

2. Denham to Monkey Mia and Ocean Park and return.

- Pick up Denham 7:30 am
- Monkey Mia for Dolphin Experience and Breakfast
- Ocean Park tour and coffee
- Return to Denham
- \$245.00 (includes breakfast and coffee)

3. Afternoon tours are options 1 or 2 with pickup time of 12:30 pm.

4. Sunset Tours by request with pick up time of 5:30 pm. Half hour Tour then to a watering hole for a feed and drinks. Return ride home to your accommodation. \$180.00 (includes meal and 2 drinks).



For a list of our tours, please turn over
Pick up at Monkey Mia is at Reception
Pick up point in Denham is at the Shark Bay Hotel (The Old Pub)
Pick up points can be requested.



SHARK BAY HARLEY TOURS

For bookings, please ring or email Wayne. Check us out on Face Book @ Shark Bay Harley Tours

0439 347 683

0439 347 683

moby@outlook.com.au

SHARK BAY NEWS AND GIFTS



- ▷ Newspapers
- ▷ Magazines
- ▷ Lotto
- ▷ Souvenirs
- ▷ Stationery
- ▷ Cards
- ▷ Gifts
- ▷ Men's & Women's fashion
- ▷ Clothing including Billabong & Betty Basics

OPEN

Monday - Friday:
8am til 5pm

Saturday:
8am til 1pm

Sunday:
9am til 12pm



Shark Bay News & Gifts - Shark Bay Pharmacy
51 Knight Terrace
Denham, Shark Bay, WA 6537
T: 9948 1220 - F: 9948 1017

Northern Glass

0458 255 261

We supply and install all your windows and we are also pleased to help you out with:

- Shower screens
- Security doors and screens
- Replace locks
- Installation of pet doors
- Flywire replacement
- Replacement of roller wheels
- Bug strips and seals
- Aluminium angle
- Perspex
- Wide range of spare parts

Johan Bakker
T: 0458 255 261 E: sharkbayglass@gmail.com

CORAL COAST PLUMBING

GAS & WATER SUPPLY, REPAIRS & LEAKS, BLOCKAGES, HOT WATER UNITS

DENHAM AREA

'SUPPORT YOUR LOCAL PLUMBER'

VAUGHAN BEAVIS

0417 301 397

OFFICE: 0899412881 PL 6759 GF017276



FOR ALL YOUR ELECTRICAL REQUIREMENTS

RESIDENTIAL UPGRADES
AIRCONDITIONING INSTALLATION AND REPAIRS
RENOVATIONS
COMMERCIAL
INDUSTRIAL
DATA/PHONE/NETWORK
MAINTENANCE AND SERVICING
FREE QUOTES



Ashley Byrnes

0456489050

EC13059



The Gascoyne's truly local radio stations

For very affordable advertising and FREE community notices
call 9941 2223 or email sales@hothits997.com



**Classic
Hits 666AM**



SELF-DRIVE 4WD HIRE

Francois Peron

NATIONAL PARK

Francois Peron National Park is an untouched coastal wonderland where red sand cliffs meet pure white sandy beaches and azure blue water. With numerous crystal clear lagoons, abundant sea life, emus and kangaroos this is a real 4WD Adventure!



24-Hours 4WD Rental from our Denham Office

BOOK: 1 800 24 68 69

Email: online@wickedcampers.com
wickedcampers.com.au



TERMS & CONDITIONS OF PROMOTION: *Monkey Mia 4WD Vehicles are to be collected and returned to Wicked Denham office only, with a full tank of fuel. Hirer is fully responsible for the vehicle while on hire, and any subsequent towing or recovery costs are to be borne by hirer. Vehicle must be returned clean (vacuumed sand-free and exterior wash), a \$200 Cleaning Fee will apply to unclean vehicles. All prices shown do NOT include State Government National Park Entry & Camping Fees (these are payable upon entry to the park). Promotion is subject to availability and may be withdrawn without notice. PLEASE NOTE: A \$500 Bond will be required prior to or upon collection of the vehicle at our Denham Office.

(Geraldton)
Pest-A-Kill WA
 We can get rid of those unwanted pests!!

Spiders	Fleas
Cockroaches	Bees
Carpet Beetles	Ants
Lawn Beetles	Ticks
Rodents	Termites

Contact us on Free Call
1800 655 989
 Email: mail@pestakill.com.au
 Domenic & Denelle Micono - 08 9965 3330

CDH ELECTRICAL

Commercial & Domestic
 Electrical & Data needs

- AIR CON sanitisation
- Breakdowns
- Installations
- Maintenance
- Repairs
- Satellite services incl. VAST & Foxtel
- Data & network cabling

DAVE HARROWER
 0429 998 944 | 9948 3289
 4 Wear Place, Denham
 cdhelectrics@gmail.com

NOW SPECIALISING IN
 all types of air conditioning and refrigeration
 maintenance and installation.
AIR COND sanitisation and servicing.

71 KNIGHT TERRACE
DENHAM
 WESTERN AUSTRALIA
 (08) 9948 3429

Surf n Dolphin

One Stop Shop

- Ladies, men's & children's clothing
- Swim wear,
- Thongs
- Hats
- Sunglasses
- Beach Goods
- Sporting Goods
- Kids toys
- USB flash drives
- Souvernirs
- Information
- Australia made
- Fishing shirts (50% OFF)
- ... and more

Top Brands Surfwear

LOOK Clothes still going out at **50% OFF** Special Rack!

New Winter Stock Now in Store!

FRIENDLY SERVICE

OPEN 7 DAYS FROM 8AM

PRODUCTS FOR ALL AGES

OPEN 7 DAYS FROM 8AM



**Automotive and Motorcycle Repairs
Qualified Mechanics**

**Panel and Paint Repairs
All Recognised Insurance Repairs**

Tilt Tray Towing

Windscreen Replacements

Radiator Specialist

Automotive Batteries

Tyre Service: Fit / Balance / Align

Mick Ricetti
52 Vlamingh Crescent
Denham WA 6537
Mick: 0427 333 590
Michael: 0467 670 136
Email: outback.coast.autos@bigpond.com



**REMEMBER TO
COVER YOUR LOAD**



**PENALTIES APPLY FOR UNCOVERED LOADS
AND LITTERING**

The Shire of Shark Bay employees work very hard to keep Denham tidy. Please help us to maintain the cleanliness of the town by transporting waste to the refuse disposal site responsibly. Do the right thing cover or secure your load.

**IF YOU DON'T YOU MAY BE SUBJECT
TO SUBSTANTIAL LITTERING FINES**

kTi

Safety Alert

Personal Locator Beacon - PLB

Keep yourself safe

**FOR SALE
at the CRC**
all profits go to your
Shark Bay SES unit

**\$340
each**

FEATURES
PROVIDES SIX INDEPENDENT
MEANS OF RESCUE:

- ✓ 406MHZ TRANSMISSION
- ✓ 121.5MHZ HOMING SIGNAL
- ✓ GPS LOCATION
- ✓ VISUAL STROBE
- ✓ SIGNAL MIRROR
- ✓ WHISTLE ON LANYARD



MANUFACTURED IN AUSTRALIA
www.kti.com.au

CONVERT
your old Videos to DVDs



from

& Records to CDs



from **\$15**

Contact the
Community Resource Centre
for more information





'We believe all animals deserve an **EXCEPTIONAL** life!'



VET

Guaranteed **GOLD**
standard vet care &
awesome customer
service at every visit!

vet hospital - boarding - grooming - merchandise - acupuncture



12 BASSETT WAY CARNARVON

www.coralcoastvet.com.au
admin@coralcoastvet.com.au

24 hour emergency service

99411155

MIDWEST COURIERS



*Providing your transport solutions from
Geraldton to Denham and Surrounds*

For the past 6 ½ years Kalbarri Express Freight has been servicing Kalbarri and surrounding areas. After enquiries were made we are going to offer our same services to Denham, with a once a week service, delivering on a Friday. Hence Midwest Couriers was born.

As Kalbarri has grown to know our reliable, efficient and friendly service we would like to offer Denham the same reliable, efficient and friendly service.

We are a small business with a hard-working team to give you the best possible service we are able to give.

Find us on our Facebook Page as well <https://www.facebook.com/Midwest-Couriers-185206275526497/>

Please call **0459 499 230** to discuss your requirements

Sudoku time

Difficulty rating: Easy

Difficulty rating: Medium

		3			4		2
		7			5		
2				4		9	
9	8		5		1	3	4
		6	4		3	9	
	3	4	2		6		7
	7			6			3
		8				7	
3		9				6	

				3			9	7
1		9		2	7		6	3
						4		
	3		1			7	4	
	2			9			5	
	1	7			3		8	
		1						
4	7			2	6		9	8
8	9				7			

CRC EDITORIAL POLICY & ADVERTISING

EDITORIAL POLICY

The Inscription Post is produced monthly by the Shark Bay Community Resource Centre in good faith as a means of providing information to the community and to promote the Shark Bay area positively.

An Editorial Management Committee of the Inscription Post has been delegated the

responsibility of the editorial role of the Inscription Post and is supported by the Management Committee. All materials submitted by the community are to be factual and non discriminatory. The Editorial Management Committee has the right to edit any items submitted for print, including abbreviating, spelling, grammar and also may

withhold or not print at all, any material considered unsuitable or offensive with no explanation needed.

We are more than happy to accept articles free of charge (subject to the Editorial Management Committee's approval), but limited space is available, so please keep submissions short – a maximum of one page unless

prior approval is granted by the Editorial Management Committee. The author's name must be supplied for any contribution. The articles printed in the newsletter do not necessarily reflect the views of the Editorial Management Committee, staff or volunteers or management committee at the Shark Bay Community Resource Centre.

The Inscription Post is available for purchase from:

- Denham IGA X-Press
- Discovery Centre
- Shark Bay News & Gifts
- Shark Bay Supermarket
- Surf n Dolphin Gift Shop
- Useless Loop

If you are interested in selling the newsletter in your store, contact the Shark Bay Community Resource Centre.

1/8 Page: \$20.00
1/4 Page: \$30.00
1/2 Page: \$50.00
Full Page: \$75.00
Subsequent pages: \$60.00

A discount of 1 month cost applies to advertisements which are paid for the full 12 months in advance. We are happy to design your advert! Do not hesitate to contact us. All cancellations of adverts must be received in writing at the Resource Centre.

The Inscription Post costs \$2 to purchase. This price covers the cost of paper and printing expenses. Postal Subscriptions: \$80.00 per annum

Please address all enquiries and correspondence to: The Editorial Management Committee - Inscription Post Shark Bay Community Resource Centre. PO Box 58, Denham WA 6537 Telephone: 08 9948 1787 - Facsimile: 08 9948 1823 sharkbay@crc.net.au

The DEADLINE for submissions into the Inscription Post is the 25th of each month

Please send your articles to: sharkbay@crc.net.au



In our region **AUTOMATED EXTERNAL DEFIBRILLATORS (AED)** are located at

- SHARK BAY DISCOVERY CENTRE
- SHARK BAY RECREATION CENTRE
- PARKS & WILDLIFE, KNIGHT TCE OFFICE
- SHARK BAY HOTEL
- DENHAM IGA
- SHARK BAY BOWLING, SPORT & RECREATION CLUB
- OCEAN PARK AQUARIUM
- MONKEY MIA BOUGHSHED RESTAURANT
- HAMELIN OUTBACK STATION STAY
- OVERLANDER ROADHOUSE
- BILLABONG ROADHOUSE
- NERREN NERREN 24HR STOP

The Chain of Survival

- **Early Access:** Recognise an emergency and call 000 **IMMEDIATELY**.
- **Early CPR:** Begin Cardio Pulmonary Resuscitation (CPR) **IMMEDIATELY**
- **Early Defibrillation:** Use the Automated External Defibrillator (AED) ASAP
- **Early Advanced Care:** Transfer to professional care.



Silver Chain

Western Australia

Silver Chain Shark Bay

Normal business hours

Monday to Friday

(excluding public holidays)

9.00am to 12.30pm

& 1.30pm to 4.00pm

Telephone: 9948 1400

**Silver Chain provides
AFTER HOURS health services
for EMERGENCIES ONLY**

After Hours Emergencies

EMERGENCY

If you call the Shark Bay Health Centre after hours you will be transferred through to Health Direct where a Registered Nurse will ask you a number of questions to determine whether you need further emergency assessment by the Shark Bay nurse. If you require further assessment, your call will be put through to the local nurse.

Examples of an EMERGENCY include:

- Breathing difficulties
- Chest pain
- Severe abdominal pain
- Bleeding that can't be controlled with first aid
- Convulsions and fits
- Deep lacerations
- Eye or ear injuries
- Uncontrolled high fever
- Loss of consciousness
- Pregnancy – bleeding or onset of labour
- A very sick child

SEPTEMBER 2019

Monday	Tuesday	Wednesday	Thursday	Friday	Saturday	Sunday
<ul style="list-style-type: none"> • 1pm Bridge Club • 6.30pm Night sports 	<ul style="list-style-type: none"> • 9.30am Kindy Gym • 1.30-3.30pm Crafters • 5pm CRC Heart Foundation Walking Group • 5.30pm Furies • 6.30pm Night Sports 	<ul style="list-style-type: none"> • 10am Denham Seniors • 10am-2pm: SJA ambulance office open • 6.30pm Night sports • 7.30pm SB Christian Fellowship - Bible Study 	<ul style="list-style-type: none"> • 10am-2pm: SJA ambulance office open • 3pm St Andrews Church - Bible Study • 5pm SES • 6pm - 7pm Youth Group Dodge Ball 	<ul style="list-style-type: none"> • 1pm Bridge Club 		<ul style="list-style-type: none"> • 9am St Andrews Church Service • 9:30am Denham Community Church (at the Rec Centre) • 10am SB Christian Fellowship, on the foreshore
2	3	4	5	6	7	8
<ul style="list-style-type: none"> • 1pm Bridge Club • 6.30pm Night sports • Chyroptractor at the CRC 	<ul style="list-style-type: none"> • 1.30-3.30pm Crafters • 5pm CRC Heart Foundation Walking Group • 5.30pm Furies • 6.30pm Night Sports 	<ul style="list-style-type: none"> • 10am-2pm: SJA ambulance office open • 10am Denham Seniors • 6.30pm Night sports • 7.30pm SB Christian Fellowship - Bible Study 	<ul style="list-style-type: none"> • 10am-2pm: SJA ambulance office open • 3pm St Andrews Church - Bible Study • 6pm - 7pm Youth Group Dodge Ball • 6pm - 6.30pm Mikayla J at SB Caravan Park 	<ul style="list-style-type: none"> • 1pm Bridge Club • 1pm Invitation to Celebrate Auntie Nellie's life 	<ul style="list-style-type: none"> • 2:15pm SB Bowling Club Scroungers 	<ul style="list-style-type: none"> • 9am St Andrews Church Service • 9:30am Denham Community Church (at the Rec Centre) • 10am SB Christian Fellowship, on the foreshore • 3-5pm "Life Drawing Group" with the Shark Bay Arts Council
9	10	11	12	13	14	15
<ul style="list-style-type: none"> • 1pm Bridge Club • 6.30pm Night sports • 2pm SCHOOL EARLY CLOSE 	<ul style="list-style-type: none"> • 1.30-3.30pm Crafters • 5pm CRC Heart Foundation Walking Group • 5.30pm Furies • 6.30pm Night Sports 	<ul style="list-style-type: none"> • 10am-2pm: SJA ambulance office open • 10am Denham Seniors • 6.30pm Night sports • 7.30pm SB Christian Fellowship - Bible Study 	<ul style="list-style-type: none"> • 10am-2pm: SJA ambulance office open • 3pm St Andrews Church - Bible Study • 5pm SES • 6pm - 7pm Youth Group Dodge Ball 	<ul style="list-style-type: none"> • 1pm Bridge Club 	<ul style="list-style-type: none"> • 2:15pm SB Bowling Club Scroungers 	<ul style="list-style-type: none"> • 9am St Andrews Church Service • 9:30am Denham Community Church (at the Rec Centre) • 10am SB Christian Fellowship, on the foreshore
16	17	18	19	20	21	22
<ul style="list-style-type: none"> • 1pm Bridge Club • 6.30pm Night sports 	<ul style="list-style-type: none"> • 1.30-3.30pm Crafters • 5pm CRC Heart Foundation Walking Group • 5.30pm Furies • 6.30pm Night Sports 	<ul style="list-style-type: none"> • 10am-2pm: SJA ambulance office open • 10am Denham Seniors • 6.30pm Night sports • 7.30pm SB Christian Fellowship - Bible Study 	<ul style="list-style-type: none"> • 10am-2pm: SJA ambulance office open • 3pm St Andrews Church - Bible Study • 6pm - 7pm Youth Group Dodge Ball 	<ul style="list-style-type: none"> • 1pm Bridge Club 	<ul style="list-style-type: none"> • 2:15pm SB Bowling Club Scroungers 	<ul style="list-style-type: none"> • 9am St Andrews Church Service • 9:30am Denham Community Church (at the Rec Centre) • 10am SB Christian Fellowship, on the foreshore
23	24	25	26	27	28	29
<ul style="list-style-type: none"> • 1pm Bridge Club • 6.30pm Night sports • 2pm SCHOOL EARLY CLOSE <p>INSCRIPTION POST ARTICLES DUE</p>	<ul style="list-style-type: none"> • 9.30am Kindy Gym • 1.30-3.30pm Crafters • 5pm CRC Heart Foundation Walking Group • 6.30pm Night Sports 	<ul style="list-style-type: none"> • 10am-2pm: SJA ambulance office open • 10am Denham Seniors • 6.30pm Night sports • 7.30pm SB Christian Fellowship - Bible Study <p>SHIRE COUNCIL MEETING</p>	<ul style="list-style-type: none"> • 10am-2pm: SJA ambulance office open • 3pm St Andrews Church - Bible Study 	<ul style="list-style-type: none"> • 1pm Bridge Club • SCHOOL Term 3 ENDS 		
30	31					
<ul style="list-style-type: none"> • 1pm Bridge Club • 5pm SES • 6.30pm night sports <p>QUEENS BIRTHDAY</p>	<ul style="list-style-type: none"> • 9.30am Kindy Gym • 1.30-3.30pm Crafters • 5pm CRC Heart Foundation Walking Group • 5.30pm Furies • 6.30pm Night Sports 					

Shark Bay Youth Group

DENHAM WA 6537

sharkbayyouthgroup@outlook.com

0409 331 728 (Bec - Chairperson)



PARTICIPATION REGISTRATION FORM

Shark Bay Youth Group, in conjunction with Muscular Dystrophy Australia will be doing a "March with Me Mates for Muscles Super Hero Walk".

SBYG are committed to providing opportunities for our youth to support not just those in Denham, but ALL Australians in need.

We use our muscles every day to do things like walk, run and even breathe, but that privilege is slowly being stolen from people who are affected by muscle wasting conditions. We will be walking to raise funds for children and adults with muscle-wasting conditions.

When: Sunday 15th September 2019

Time: 10am - 12noon

Starting / End Point: BBQ HUT near Shark Bay Supermarket

Cost: \$10 per person (this money will be sent directly to Muscular Dystrophy Australia.

PARTICIPANTS ARE ENCOURAGED TO COME DRESSED AS SUPER HERO'S.

Participants will need to walk approximately 6.6km around Stella Rowley Drive.

The first 60 participants to register will receive a free Super Hero Cape and Mask!

Participants will receive a free sausage sizzle at the completion of their walk.

To register, please complete the attached form and return with payment of \$10 per person to Shark Bay Youth Group. All participants aged 18 and under must have a parent sign their registration form. Any participant aged 12 and under must have a parent or responsible adult walk with them for the duration of the event.

March with Me Mates for Muscles Super Hero Walk

Registration Form

Names of participants;

1). _____ Age: _____

2). _____ Age: _____

3). _____ Age: _____

4). _____ Age: _____

5). _____ Age: _____

By signing below I/we agree to;

* walk as far away from the road verge as is practical.

* give permission for my/our images to be used to promote Shark Bay Youth Group and Muscular Dystrophy.

* be in control of any children aged 12 and under in my care for the duration of the event.

* give permission for my children aged 12 - 18 to participate, I have instructed my children to follow all road safety rules, to following directions by event organisers and to participate as safely as practical at all times.

* agree to pay \$10 per participant. Payment can be made by cash or direct deposit.

Bank details are: BSB: 066 509 Account No: 10185926

Parent / Guardian signature: _____ Date: _____





COMBINED SINGLE / DOUBLE NAME PAVER & HAND DRAWN IMAGE TEMPLATE

Shark Bay P & C Association

Help the Shark Bay P & C Association as we build your own piece of history at the Shark Bay School as we develop our community support name paver pathway.



OFFER 1: \$35
SINGLE PAVER

Your donation of \$35 entitles you to have your name engraved into a paver as a permanent record of your valued support. The paver will be permanently installed along a pathway at Shark Bay School, proudly showing your support.



OFFER 2: \$40
HAND DRAWN PAVERS

Your donation of \$40 entitles you to have your hand drawn image engraved into a paver as a lasting record of your valued support. The paver will be permanently installed along a pathway at Shark Bay School, proudly showing your support.

NAME PAVERS ARE:

- A unique and lasting record of your support;
- A creation of memories and milestones;
- A tribute to someone special or a precious memorial to a loved one.

Simply fill out this form and return it to the Shark Bay School office along with full payment by cheque, cash or EFT to:

**Shark Bay P&C Association,
Francis Street
DENHAM WA 6537**

Banking details for funds transfers

Shark Bay P&C Association Inc
BSB: 066 509
Account Number: 00903066

Contact Name

Phone

Address

Suburb/Town

State

Post Code

Offer 1

Offer 2

Our Donation

\$

Offer closes on Friday, 16th August 2019

Please copy and pass on to any friends & family.
WE NEED YOUR SUPPORT!

Call 0427 272 560 (Jamie Burton) for any queries.



COMBINED SINGLE & HAND DRAWN IMAGE TEMPLATE

Single Paver engraving details - \$35

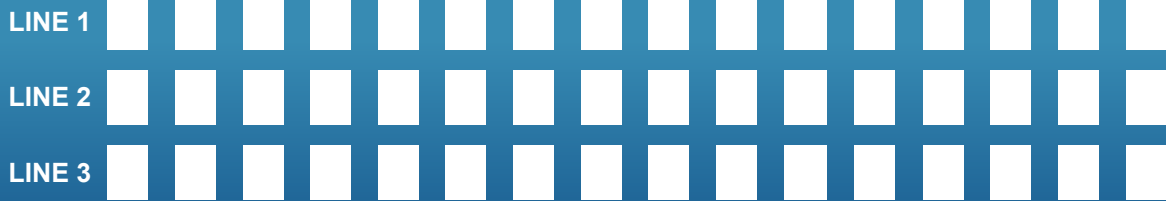

Hand Drawn Paver engraving details - \$40

PLEASE FOLLOW THESE SIMPLE STEPS WHEN CREATING YOUR IMAGE.

1. ONE NAME PER PAVER.
2. Draw your image using a good quality medium thickness black marker pen (about 2mm thick). eg Artline 70 'High Performance' marker, **Do not use a ballpoint pen, coloured text or pencils!**
3. Make sure you rub out any pencil lines as these will show up on the finished paver.
4. Do not include computer-generated or pasted pictures as we can only engrave hand drawn images only.

SAMPLE 1



- THIS IS OK ✓**
- Good clean writing
 - Simple illustrations

SAMPLE 2

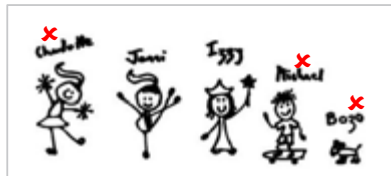

- THIS IS NOT OK ✗**
- Too many names
 - Illustrations too detailed
 - Information gets lost

SAMPLE 3

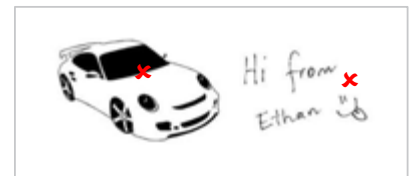

- THIS IS NOT OK ✗**
- Do not include computer-generated or pasted pictures
 - The process is set up to engrave hand drawn images only

PLEASE ENSURE THAT YOUR DRAWING DOES NOT TOUCH OR GO OUTSIDE OF THE BORDER

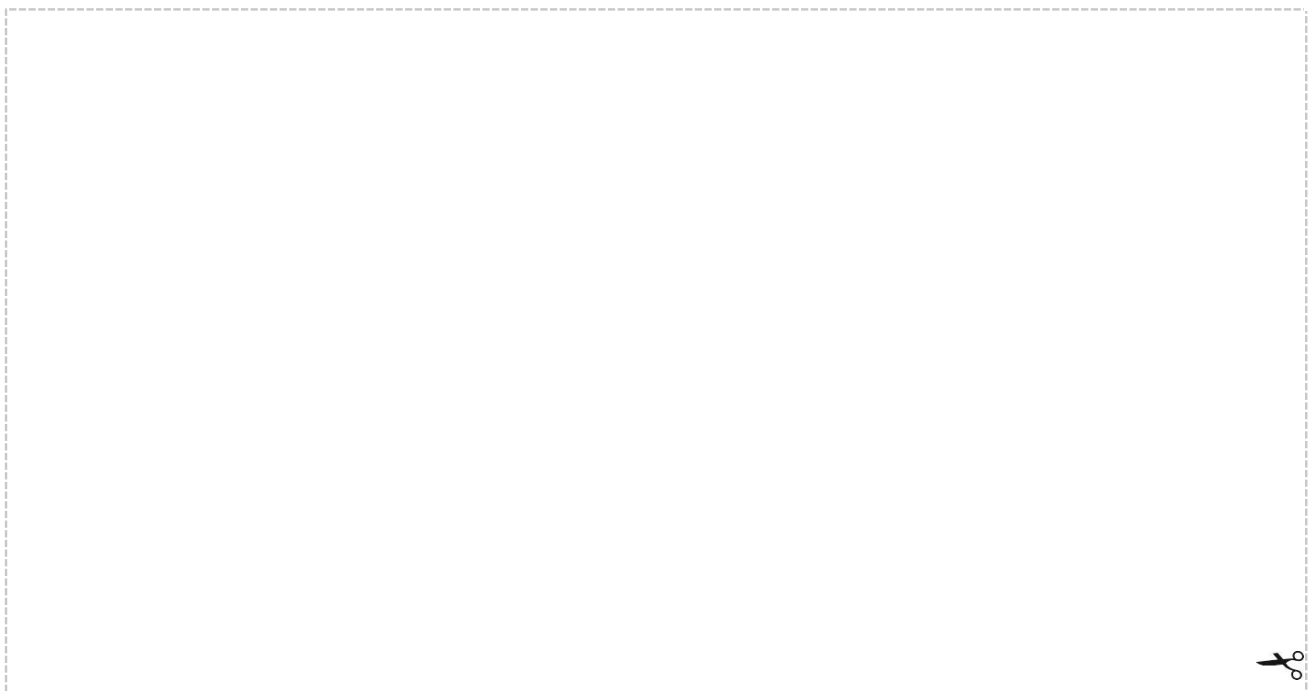

100mm high x 190mm wide